

Models:  
ST-36TR-IPI  
ST-36TRLP-IPI  
PIER-36TR-IPI  
PIER-36TRLP-IPI

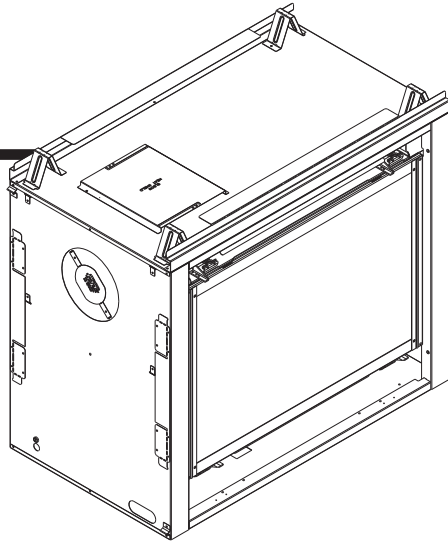

### NOTICE



#### DO NOT DISCARD THIS MANUAL

- Important operating and maintenance instructions included.
- Read, understand and follow these instructions for safe installation and operation.
- Leave this manual with party responsible for use and operation.



**⚠ WARNING:** If the information in these instructions is not followed exactly, a fire or explosion may result causing property damage, personal injury, or death.

- **DO NOT** store or use gasoline or other flammable vapors and liquids in the vicinity of this or any other appliance.
- **What to do if you smell gas**
  - **DO NOT** try to light any appliance.
  - **DO NOT** touch any electrical switch. **DO NOT** use any phone in your building.
  - Immediately call your gas supplier from a neighbor's phone. Follow the gas supplier's instructions.
  - If you cannot reach your gas supplier, call the fire department.
- Installation and service must be performed by a qualified installer, service agency, or the gas supplier.

This appliance may be installed as an OEM installation in manufactured home (USA only) or mobile home and must be installed in accordance with the manufacturer's instructions and the manufactured home construction and safety standard, *Title 24 CFR, Part 3280* or *Standard for Installation in Mobile Homes, CAN/CSA Z240MH*, in Canada.

*This appliance is only for use with the type(s) of gas indicated on the rating plate.*

### ⚠ WARNING



#### HOT SURFACES!

Glass and other surfaces are hot during operation AND cool down.

#### Hot glass will cause burns.

- **DO NOT** touch glass until it is cooled
  - NEVER allow children to touch glass
  - Keep children away
  - CAREFULLY SUPERVISE children in same room as fireplace.
  - Alert children and adults to hazards of high temperatures.
- High temperatures may ignite clothing or other flammable materials.**
- Keep clothing, furniture, draperies and other flammable materials away.

***This appliance has been supplied with an integral barrier to prevent direct contact with the fixed glass panel. DO NOT operate the appliance with the barrier removed.***

Contact your dealer or Hearth & Home Technologies if the barrier is not present or help is needed to properly install one.

In the Commonwealth of Massachusetts installation must be performed by a licensed plumber or gas fitter.

See Table of Contents for location of additional Commonwealth of Massachusetts requirements.



Installation and service of this appliance should be performed by qualified personnel. Hearth & Home Technologies suggests NFI certified or factory trained professionals, or technicians supervised by an NFI certified professional.

Read this manual before installing or operating this appliance.  
Please retain this owner's manual for future reference.

## A. Congratulations

Congratulations on selecting a Heat & Glo gas fireplace, an elegant and clean alternative to wood burning fireplaces. The Heat & Glo gas fireplace you have selected is designed to provide the utmost in safety, reliability, and efficiency.

As the owner of a new fireplace, you'll want to read and carefully follow all of the instructions contained in this owner's manual. Pay special attention to all cautions and warnings.

This owner's manual should be retained for future reference. We suggest that you keep it with your other important documents and product manuals.

The information contained in this owner's manual, unless noted otherwise, applies to all models and gas control systems.

Your new Heat & Glo gas fireplace will give you years of durable use and trouble-free enjoyment. Welcome to the Heat & Glo family of fireplace products!

Homeowner Reference Information	<i>We recommend that you record the following pertinent information about your fireplace.</i>
Model Name: _____	Date purchased/installed: _____
Serial Number: _____	Location on fireplace: _____
Dealership purchased from: _____	Dealer Phone: _____
Notes: _____	
_____	

## Listing Label Information/Location

The model information regarding your specific fireplace can be found on the rating plate usually located in the control area of the fireplace.

Type of Gas →

Gas and Electric Information →

**HEAT & GLO**  
No one builds a better fire

Heat & Glo, a brand of Hearth & Home Technologies, Inc.  
7571 215th Street West, Lakeville, MN 55044

Not for use with solid fuel.  
*(Ne doit pas être utilisé avec un combustible solide).*

Type of Gas (Sorte De Gaz): **NATURAL GAS**

This appliance must be installed in accordance with local codes, if any; if not, follow ANSI Z223.1 in the USA or CAN/CGA B149 installation codes. (Installer l'appareil selon les codes ou règlements locaux ou, en l'absence de tels règlements, selon les codes d'installation CAN/CGA-B149.)

**ANSI Z21XX-XXXX - CSA 2.XX-MXX - UL307B**

Minimum Permissible Gas Supply for Purposes of Input Adjustment.

Approved Minimum (De Gaz) Acceptable	0.0 in w.c.	(Po. Col. d'eau)
Maximum Pressure (Pression)	0.0 in w.c.	(Po. Col. d'eau)
Maximum Manifold Pressure (Pression)	0.0 in w.c.	(Po. Col. d'eau)
Minimum Manifold Pressure (Pression)	0.0 in w.c.	(Po. Col. d'eau)

Total Electrical Requirements: 000Vac, 00Hz., less than 00 Amperes

**MADE IN USA**

**GAS-FIRED**



ALTITUDE:	0-0000 FT.	IN CANADA	0000-0000FT.
MAX. INPUT BTUH:	00,000		00,000
MIN. INPUT BTUH:	00,000		00,000
ORIFICE SIZE:	#XXXXXX		#XXXXXX

<b>Model:</b> (Modele):	XXXXXXXXXX
<b>Serial</b> (Serie):	XXXXXXXXXX

Model Number →

Serial Number →

## ▲ Safety Alert Key:

- **DANGER!** Indicates a hazardous situation which, if not avoided will result in death or serious injury.
- **WARNING!** Indicates a hazardous situation which, if not avoided could result in death or serious injury.
- **CAUTION!** Indicates a hazardous situation which, if not avoided, could result in minor or moderate injury.
- **NOTICE:** Used to address practices not related to personal injury.

## Table of Contents

A. Congratulations . . . . .	2
→ B. Limited Lifetime Warranty . . . . .	5

### 1 Listing and Code Approvals

A. Appliance Certification . . . . .	7
B. Tempered Glass Specifications . . . . .	7
C. BTU Specifications . . . . .	7
D. High Altitude Installations . . . . .	7
E. Non-Combustible Materials Specification . . . . .	7
F. Combustible Materials Specification . . . . .	7
G. Electrical Codes . . . . .	7
H. Requirements for the Commonwealth of Massachusetts . . . . .	8

## User Guide

### 2 Operating Instructions

A. Gas Fireplace Safety . . . . .	9
B. Your Fireplace . . . . .	9
C. Blower Kit (optional) . . . . .	10
D. Clear Space . . . . .	10
E. Decorative Doors and Fronts . . . . .	10
F. Fixed Glass Assembly . . . . .	10
G. Remote Controls, Wall Controls and Wall Switches . . . . .	10
H. Before Lighting Fireplace . . . . .	10
I. Lighting Instructions (IPI) . . . . .	11
J. After Fireplace is Lit . . . . .	12
K. Frequently Asked Questions . . . . .	12

### 3 Maintenance and Service

A. Maintenance Tasks-Homeowner . . . . .	13
→ B. Maintenance Tasks-Qualified Service Technician . . . . .	14

## Installer Guide

### 4 Getting Started

A. Typical Appliance System . . . . .	16
B. Design and Installation Considerations . . . . .	17
C. Tools and Supplies Needed . . . . .	17
D. Inspect Appliance and Components . . . . .	17

### 5 Framing and Clearances

A. Selecting Appliance Location . . . . .	18
B. Constructing the Appliance Chase . . . . .	19
C. Clearances . . . . .	19
D. Mantel and Wall Projections . . . . .	21

### 6 Termination Locations

→ A. Vent Termination Minimum Clearances . . . . .	23
B. Continue Adding Vent Components . . . . .	25
C. Install Support Brackets . . . . .	25

### 7 Vent Information and Diagrams

A. Approved Pipe . . . . .	26
B. Vent Table Key . . . . .	26
C. Use of Elbows . . . . .	26
D. Measuring Standards . . . . .	26
E. Vent Diagrams . . . . .	27

### 8 Vent Clearances and Framing

A. Pipe Clearances to Combustibles . . . . .	37
B. Wall Penetration Framing . . . . .	37
C. Vertical Penetration Framing . . . . .	38
D. Install Attic Insulation Shield . . . . .	39

### 9 Appliance Preparation

A. Top Vent . . . . .	40
B. Rear Vent . . . . .	41
C. Securing and Leveling the Appliance . . . . .	42

### 10 Installing Vent Pipe (DVP and SLP Pipe)

A. Assemble Vent Sections (DVP Pipe Only) . . . . .	43
B. Assemble Vent Sections (SLP Pipe Only) . . . . .	44
C. Assemble Slip Sections . . . . .	44
D. Secure the Vent Sections . . . . .	45
E. Disassemble Vent Sections . . . . .	45
F. Install Decorative Ceiling Components (SLP only) . . . . .	46
G. Install Metal Roof Flashing . . . . .	47
H. Assemble and Install Storm Collar . . . . .	47
I. Install Vertical Termination Cap . . . . .	48
J. Install Decorative Wall Components (SLP only) . . . . .	48
K. Heat Shield Requirements for Horizontal Termination . . . . .	48
L. Install Horizontal Termination Cap (DVP and SLP Pipe) . . . . .	49

### 11 Gas Information

A. Fuel Conversion . . . . .	50
B. Gas Pressure . . . . .	50
C. Gas Connection . . . . .	50
D. High Altitude Installations . . . . .	50

### 12 Electrical Information

A. Wiring Requirements . . . . .	51
B. IntelliFire Ignition System Wiring . . . . .	51
C. Electrical Service and Repair . . . . .	51
D. Junction Box Installation . . . . .	51
E. WSK-MLT Multifunction Wall Switch . . . . .	52
F. Install the Flame Solenoid . . . . .	54
G. Connect the Temperature Sensor Switch for Fan (optional) . . . . .	54
H. WSK-MLT Operating Instructions . . . . .	55
I. Setting Flame Height/Manifold Pressure . . . . .	55
J. Wall Switch Button Operation . . . . .	55

### 13 Finishing

A. Splatter Guard . . . . .	57
B. Mantel and Wall Projections . . . . .	59
C. Facing Material . . . . .	60
D. Finishing Material . . . . .	61
E. Elevated Hearth Systems . . . . .	63

### 14 Appliance Setup

A. Remove Fixed Glass Assembly . . . . .	64
B. Remove the Shipping Materials . . . . .	64
C. Clean the Appliance . . . . .	64
D. Accessories . . . . .	64
E. Lava Rock/Teco-Sil and Glowing Ember Placement . . . . .	64
F. Install the Log Assembly . . . . .	66
G. Fixed Glass Assembly . . . . .	69
H. Install Trim Kits and Surrounds . . . . .	69
I. Air Shutter Setting . . . . .	69

### 15 Troubleshooting

➔ A. IntelliFire Ignition System . . . . .	70
--	----

### 16 Reference Materials

A. Appliance Dimension Diagram . . . . .	72
➔ B. Vent Components Diagrams . . . . .	74
➔ C. Service Parts List . . . . .	84
D. Contact Information . . . . .	85

➔ = Contains updated information.

→ **B. Limited Lifetime Warranty**

**Hearth & Home Technologies Inc.  
LIMITED LIFETIME WARRANTY**

Hearth & Home Technologies Inc., on behalf of its hearth brands ("HHT"), extends the following warranty for HHT gas, wood, pellet, coal and electric hearth appliances that are purchased from an HHT authorized dealer.

**WARRANTY COVERAGE:**

HHT warrants to the original owner of the HHT appliance at the site of installation, and to any transferee taking ownership of the appliance at the site of installation within two years following the date of original purchase, that the HHT appliance will be free from defects in materials and workmanship at the time of manufacture. After installation, if covered components manufactured by HHT are found to be defective in materials or workmanship during the applicable warranty period, HHT will, at its option, repair or replace the covered components. HHT, at its own discretion, may fully discharge all of its obligations under such warranties by replacing the product itself or refunding the verified purchase price of the product itself. The maximum amount recoverable under this warranty is limited to the purchase price of the product. This warranty is subject to conditions, exclusions and limitations as described below.

**WARRANTY PERIOD:**

Warranty coverage begins on the date of original purchase. In the case of new home construction, warranty coverage begins on the date of first occupancy of the dwelling or six months after the sale of the product by an independent, authorized HHT dealer/ distributor, whichever occurs earlier. The warranty shall commence no later than 24 months following the date of product shipment from HHT, regardless of the installation or occupancy date. The warranty period for parts and labor for covered components is produced in the following table.

The term "Limited Lifetime" in the table below is defined as: 20 years from the beginning date of warranty coverage for gas appliances, and 10 years from the beginning date of warranty coverage for wood, pellet, and coal appliances. These time periods reflect the minimum expected useful lives of the designated components under normal operating conditions.

Warranty Period		HHT Manufactured Appliances and Venting							Components Covered
Parts	Labor	Gas	Wood	Pellet	EPA Wood	Coal	Electric	Venting	
1 Year		X	X	X	X	X	X	X	All parts and material except as covered by Conditions, Exclusions, and Limitations listed
2 years				X	X	X			Igniters, electronic components, and glass
		X	X	X	X	X			Factory-installed blowers
			X						Molded refractory panels
3 years				X					Firepots and burnpots
5 years	1 year			X	X				Castings and baffles
7 years	3 years		X	X	X				Manifold tubes, HHT chimney and termination
10 years	1 year	X							Burners, logs and refractory
Limited Lifetime	3 years	X	X	X	X	X			Firebox and heat exchanger
90 Days		X	X	X	X	X	X	X	All replacement parts beyond warranty period

See conditions, exclusions, and limitations on next page.

## → B. Limited Lifetime Warranty (*continued*)

### **WARRANTY CONDITIONS:**

- This warranty only covers HHT appliances that are purchased through an HHT authorized dealer or distributor. A list of HHT authorized dealers is available on the HHT branded websites.
- This warranty is only valid while the HHT appliance remains at the site of original installation.
- Contact your installing dealer for warranty service. If the installing dealer is unable to provide necessary parts, contact the nearest HHT authorized dealer or supplier. Additional service fees may apply if you are seeking warranty service from a dealer other than the dealer from whom you originally purchased the product.
- Check with your dealer in advance for any costs to you when arranging a warranty call. Travel and shipping charges for parts are not covered by this warranty.

### **WARRANTY EXCLUSIONS:**

This warranty does not cover the following:

- Changes in surface finishes as a result of normal use. As a heating appliance, some changes in color of interior and exterior surface finishes may occur. This is not a flaw and is not covered under warranty.
- Damage to printed, plated, or enameled surfaces caused by fingerprints, accidents, misuse, scratches, melted items, or other external sources and residues left on the plated surfaces from the use of abrasive cleaners or polishes.
- Repair or replacement of parts that are subject to normal wear and tear during the warranty period. These parts include: paint, wood, pellet and coal gaskets, firebricks, grates, flame guides, light bulbs, batteries and the discoloration of glass.
- Minor expansion, contraction, or movement of certain parts causing noise. These conditions are normal and complaints related to this noise are not covered by this warranty.
- Damages resulting from: (1) failure to install, operate, or maintain the appliance in accordance with the installation instructions, operating instructions, and listing agent identification label furnished with the appliance; (2) failure to install the appliance in accordance with local building codes; (3) shipping or improper handling; (4) improper operation, abuse, misuse, continued operation with damaged, corroded or failed components, accident, or improperly/incorrectly performed repairs; (5) environmental conditions, inadequate ventilation, negative pressure, or drafting caused by tightly sealed constructions, insufficient make-up air supply, or handling devices such as exhaust fans or forced air furnaces or other such causes; (6) use of fuels other than those specified in the operating instructions; (7) installation or use of components not supplied with the appliance or any other components not expressly authorized and approved by HHT; (8) modification of the appliance not expressly authorized and approved by HHT in writing; and/or (9) interruptions or fluctuations of electrical power supply to the appliance.
- Non-HHT venting components, hearth components or other accessories used in conjunction with the appliance.
- Any part of a pre-existing fireplace system in which an insert or a decorative gas appliance is installed.
- HHT's obligation under this warranty does not extend to the appliance's capability to heat the desired space. Information is provided to assist the consumer and the dealer in selecting the proper appliance for the application. Consideration must be given to appliance location and configuration, environmental conditions, insulation and air tightness of the structure.

### **This warranty is void if:**

- The appliance has been over-fired or operated in atmospheres contaminated by chlorine, fluorine, or other damaging chemicals. Over-firing can be identified by, but not limited to, warped plates or tubes, rust colored cast iron, bubbling, cracking and discoloration of steel or enamel finishes.
- The appliance is subjected to prolonged periods of dampness or condensation.
- There is any damage to the appliance or other components due to water or weather damage which is the result of, but not limited to, improper chimney or venting installation.

### **LIMITATIONS OF LIABILITY:**

- The owner's exclusive remedy and HHT's sole obligation under this warranty, under any other warranty, express or implied, or in contract, tort or otherwise, shall be limited to replacement, repair, or refund, as specified above. In no event will HHT be liable for any incidental or consequential damages caused by defects in the appliance. Some states do not allow exclusions or limitation of incidental or consequential damages, so these limitations may not apply to you. This warranty gives you specific rights; you may also have other rights, which vary from state to state. EXCEPT TO THE EXTENT PROVIDED BY LAW, HHT MAKES NO EXPRESS WARRANTIES OTHER THAN THE WARRANTY SPECIFIED HEREIN. THE DURATION OF ANY IMPLIED WARRANTY IS LIMITED TO DURATION OF THE EXPRESSED WARRANTY SPECIFIED ABOVE.



# 1 Listing and Code Approvals

## A. Appliance Certification

**MODELS:** ST-36TR-IPI, ST-36TRLP-IPI, PIER-36TR-IPI, PIER-36TRLP-IPI

**LABORATORY:** Underwriters Laboratories, Inc. (UL)

**TYPE:** Direct Vent Gas Appliance Heater

**STANDARD:** ANSI Z21.88-2007 • CSA 2.33a-2007

This product is listed to ANSI standards for “Vented Gas Appliance Heaters” and applicable sections of “Gas Burning Heating Appliances for Manufactured Homes and Recreational Vehicles”, and “Gas Fired Appliances for Use at High Altitudes”.

**NOTICE:** This installation must conform with local codes. In the absence of local codes you must comply with the National Fuel Gas Code, ANSI Z223.1-latest edition in the U.S.A. and the CAN/CGA B149 Installation Codes in Canada.

**NOT INTENDED FOR USE AS A PRIMARY HEAT SOURCE.**

This appliance is tested and approved as either supplemental room heat or as a decorative appliance. It should not be factored as primary heat in residential heating calculations.

## B. Tempered Glass Specifications

Hearth & Home Technologies appliances manufactured with tempered glass may be installed in hazardous locations such as bathtub enclosures as defined by the Consumer Product Safety Commission (CPSC). The tempered glass has been tested and certified to the requirements of **ANSI Z97.1** and **CPSC 16 CFR 1202** (Safety Glazing Certification Council **SGCC# 1595** and **1597**. Architectural Testing, Inc. Reports **02-31919.01** and **02-31917.01**).

This statement is in compliance with **CPSC 16 CFR Section 1201.5** “Certification and labeling requirements” which refers to **15 U.S. Code (USC) 2063** stating “...Such certificate shall accompany the product or shall otherwise be furnished to any distributor or retailer to whom the product is delivered.”

Some local building codes require the use of tempered glass with permanent marking in such locations. Glass meeting this requirement is available from the factory. Please contact your dealer or distributor to order.

## C. BTU Specifications

Models (U.S. or Canada)	Maximum Input BTU/h	Minimum Input BTU/h	Orifice Size (DMS)	
<b>ST-36TR-IPI</b> <b>PIER-36TR-IPI</b>	US (0-2000 FT)	37,000	26,000	32
	CANADA (2000-4500 FT)	34,500	23,900	33
<b>ST-36TRLP-IPI</b> <b>PIER-36TRLP-IPI</b>	US (0-2000 FT)	36,000	27,000	50
	CANADA (2000-4500 FT)	32,400	24,300	51

## D. High Altitude Installations

**NOTICE:** If the heating value of the gas has been reduced, these rules do not apply. Check with your local gas utility or authorities having jurisdiction.

When installing above 2000 feet elevation:

- In the USA: Reduce input rate 4% for each 1000 feet above 2000 feet.
- In CANADA: Reduce input rate 10% for elevations between 2000 feet and 4500 feet. Above 4500 feet, consult local gas utility.

Check with your local gas utility to determine proper orifice size.

## E. Non-Combustible Materials Specification

Material which will not ignite and burn. Such materials are those consisting entirely of steel, iron, brick, tile, concrete, slate, glass or plasters, or any combination thereof.

Materials that are reported as passing **ASTM E 136, Standard Test Method for Behavior of Materials in a Vertical Tube Furnace at 750 °C** and **UL763** shall be considered non-combustible materials.

## F. Combustible Materials Specification

Materials made of or surfaced with wood, compressed paper, plant fibers, plastics, or other material that can ignite and burn, whether flame proofed or not, or plastered or unplastered shall be considered combustible materials.

## G. Electrical Codes

**NOTICE:** This appliance must be electrically wired and grounded in accordance with local codes or, in the absence of local codes, with **National Electric Code ANSI/NFPA 70-latest edition** or the **Canadian Electric Code CSA C22.1**.

- A 110-120 VAC circuit for this product must be protected with ground-fault circuit-interrupter protection, in compliance with the applicable electrical codes, when it is installed in locations such as in bathrooms or near sinks.

**Note:** The following requirements reference various Massachusetts and national codes not contained in this document.

## H. Requirements for the Commonwealth of Massachusetts

For all side wall horizontally vented gas fueled equipment installed in every dwelling, building or structure used in whole or in part for residential purposes, including those owned or operated by the Commonwealth and where the side wall exhaust vent termination is less than seven (7) feet above finished grade in the area of the venting, including but not limited to decks and porches, the following requirements shall be satisfied:

### Installation of Carbon Monoxide Detectors

At the time of installation of the side wall horizontal vented gas fueled equipment, the installing plumber or gas fitter shall observe that a hard wired carbon monoxide detector with an alarm and battery back-up is installed on the floor level where the gas equipment is to be installed. In addition, the installing plumber or gas fitter shall observe that a battery operated or hard wired carbon monoxide detector with an alarm is installed on each additional level of the dwelling, building or structure served by the side wall horizontal vented gas fueled equipment. It shall be the responsibility of the property owner to secure the services of qualified licensed professionals for the installation of hard wired carbon monoxide detectors.

In the event that the side wall horizontally vented gas fueled equipment is installed in a crawl space or an attic, the hard wired carbon monoxide detector with alarm and battery back-up may be installed on the next adjacent floor level.

In the event that the requirements of this subdivision can not be met at the time of completion of installation, the owner shall have a period of thirty (30) days to comply with the above requirements; provided, however, that during said thirty (30) day period, a battery operated carbon monoxide detector with an alarm shall be installed.

### Approved Carbon Monoxide Detectors

Each carbon monoxide detector as required in accordance with the above provisions shall comply with NFPA 720 and be ANSI/UL 2034 listed and IAS certified.

### Signage

A metal or plastic identification plate shall be permanently mounted to the exterior of the building at a minimum height of eight (8) feet above grade directly in line with the exhaust vent terminal for the horizontally vented gas fueled heating appliance or equipment. The sign shall read, in print size no less than one-half (1/2) inch in size, "**GAS VENT DIRECTLY BELOW. KEEP CLEAR OF ALL OBSTRUCTIONS**".

## Inspection

The state or local gas inspector of the side wall horizontally vented gas fueled equipment shall not approve the installation unless, upon inspection, the inspector observes carbon monoxide detectors and signage installed in accordance with the provisions of 248 CMR 5.08(2)(a)1 through 4.

## Exemptions

The following equipment is exempt from 248 CMR 5.08(2)(a)1 through 4:

- The equipment listed in Chapter 10 entitled "Equipment Not Required To Be Vented" in the most current edition of NFPA 54 as adopted by the Board; and
- Product Approved side wall horizontally vented gas fueled equipment installed in a room or structure separate from the dwelling, building or structure used in whole or in part for residential purposes.

## MANUFACTURER REQUIREMENTS

### Gas Equipment Venting System Provided

When the manufacturer of Product Approved side wall horizontally vented gas equipment provides a venting system design or venting system components with the equipment, the instructions provided by the manufacturer for installation of the equipment and the venting system shall include:

- Detailed instructions for the installation of the venting system design or the venting system components; and
- A complete parts list for the venting system design or venting system.

### Gas Equipment Venting System NOT Provided

When the manufacturer of a Product Approved side wall horizontally vented gas fueled equipment does not provide the parts for venting the flue gases, but identifies "special venting systems", the following requirements shall be satisfied by the manufacturer:

- The referenced "special venting system" instructions shall be included with the appliance or equipment installation instructions; and
- The "special venting systems" shall be Product Approved by the Board, and the instructions for that system shall include a parts list and detailed installation instructions.

A copy of all installation instructions for all Product Approved side wall horizontally vented gas fueled equipment, all venting instructions, all parts lists for venting instructions, and/or all venting design instructions shall remain with the appliance or equipment at the completion of the installation.

**See Gas Connection section for additional Commonwealth of Massachusetts requirements.**



## A. Gas Fireplace Safety

### ⚠ WARNING



#### HOT SURFACES!

Glass and other surfaces are hot during operation AND cool down.

#### Hot glass will cause burns.

- DO NOT touch glass until it is cooled
- NEVER allow children to touch glass
- Keep children away

- CAREFULLY SUPERVISE children in same room as fireplace.
- Alert children and adults to hazards of high temperatures.

#### High temperatures may ignite clothing or other flammable materials.

- Keep clothing, furniture, draperies and other flammable materials away.

***This appliance has been supplied with an integral barrier to prevent direct contact with the fixed glass panel. DO NOT operate the appliance with the barrier removed.***

Contact your dealer or Hearth & Home Technologies if the barrier is not present or help is needed to properly install one.

If you expect that small children or vulnerable adults may come into contact with this fireplace, the following precautions are recommended:

- Install a physical barrier such as:
  - A decorative firescreen.
  - Adjustable safety gate.
- Install a switch lock or a wall/remote control with child protection lockout feature.

- Keep remote controls out of reach of children.
- Never leave children alone near a hot fireplace, whether operating or cooling down.
- Teach children to NEVER touch the fireplace.
- Consider not using the fireplace when children will be present.

Contact your dealer for more information, or visit: [www.hpba.org/safety-information](http://www.hpba.org/safety-information).

To prevent unintended operation when not using your fireplace for an extended period of time (summer months, vacations, trips, etc):

- Remove batteries from remote controls.
- Turn off wall controls.
- Unplug 3 volt adapter plug and remove batteries on IPI models.

## B. Your Fireplace

***WARNING! DO NOT operate fireplace before reading and understanding operating instructions. Failure to operate fireplace according to operating instructions could cause fire or injury.***

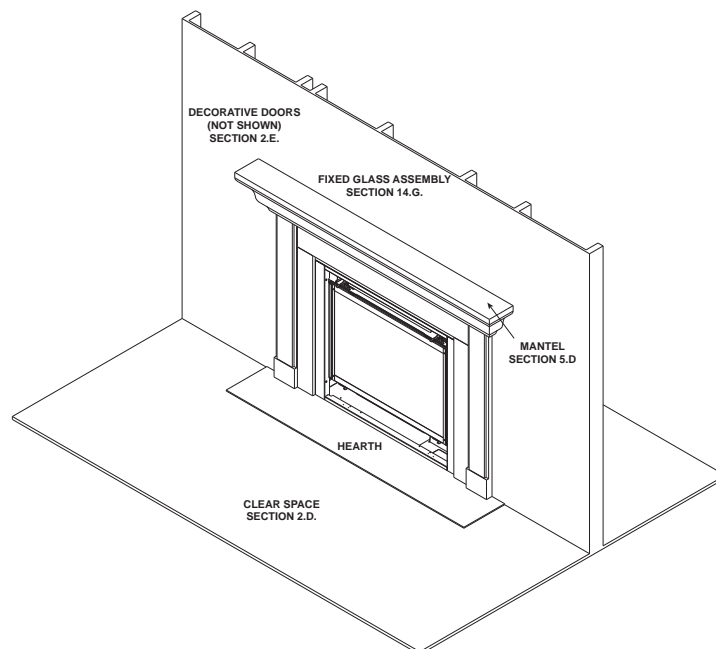

Figure 2.1 General Operating Parts

## C. Blower Kit (optional)

If desired, a blower kit may be added. Contact your dealer to order the correct blower kit.

### Blower Installation

1. Place blower in appliance as shown in Figure 2.2.
2. Wire the blower and temperature sensor as shown in Figure 12.2.
3. Attach temperature sensor switch by placing the switch onto the threaded stud indicated in Figure 2.2 and then threading the wing nut onto the stud.

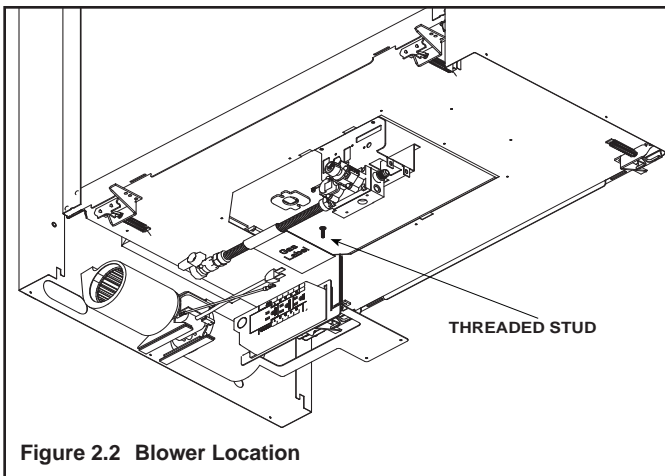

## D. Clear Space

**WARNING! DO NOT** place combustible objects in front of the fireplace or block louvers. High temperatures may start a fire. See Figure 2.3.

Avoid placing candles and other heat-sensitive objects on mantel or hearth. Heat may damage these objects.

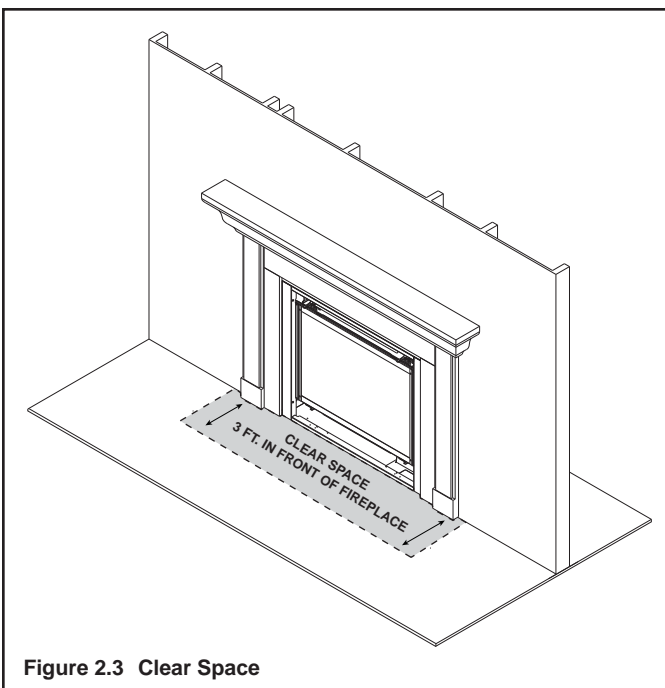

## E. Decorative Doors and Fronts

**WARNING! Risk of Fire!** Install **ONLY** doors or fronts approved by Hearth & Home Technologies. Unapproved doors or fronts may cause fireplace to overheat.

**This fireplace has been supplied with an integral barrier to prevent direct contact with the fixed glass panel. DO NOT operate the fireplace with the barrier removed.**

Contact your dealer or Hearth & Home Technologies if the barrier is not present or help is needed to properly install one.

For more information refer to the instructions supplied with your decorative door or front.

## F. Fixed Glass Assembly

See Section 14.G.

## G. Remote Controls, Wall Controls and Wall Switches

Follow the instructions supplied with the control installed to operate your fireplace:

For safety:

- Install a switch lock or a wall/remote control with child protection lockout feature.
- Keep remote controls out of reach of children.

See your dealer if you have questions.

## H. Before Lighting Fireplace

Before operating this fireplace for the first time, **have a qualified service technician:**

- Verify all shipping materials have been removed from inside and/or underneath the firebox.
- Review proper placement of logs, ember material and/or other decorative materials.
- Check the wiring.
- Check the air shutter adjustment.
- Ensure that there are no gas leaks.
- Ensure that the glass is sealed and in the proper position and that the integral barrier is in place.

**WARNING! Risk of Fire or Asphyxiation! DO NOT operate fireplace with fixed glass assembly removed.**

## I. Lighting Instructions (IPI)

The IPI system may be operated with two D-cell batteries. To prolong battery life, remove them when using the transformer.

### FOR YOUR SAFETY READ BEFORE LIGHTING

**WARNING:** If you do not follow these instructions exactly, a fire or explosion may result causing property damage, personal injury or loss of life.

- A.** This appliance is equipped with an intermittent pilot ignition (IPI) device which automatically lights the burner. **DO NOT** try to light the burner by hand.
- Immediately call your gas supplier from a neighbor's phone. Follow the gas supplier's instructions.
  - If you cannot reach your gas supplier, call the fire department.
- B. BEFORE LIGHTING,** smell all around the appliance area for gas. Be sure to smell next to the floor because some gas is heavier than air and will settle on the floor.
- C. DO NOT** use this appliance if any part has been under water. Immediately call a qualified service technician to inspect the appliance and to replace any part of the control system and any gas control which has been under water.

#### WHAT TO DO IF YOU SMELL GAS

- **DO NOT** try to light any appliance.
- **DO NOT** touch any electric switch; do not use any phone in your building.

### WARNING:

**DO NOT CONNECT LINE VOLTAGE (110/120 VAC OR 220/240 VAC) TO THE CONTROL VALVE.**

Improper installation, adjustment, alteration, service or maintenance can cause injury or property damage. Refer to the owner's information manual provided with this appliance.

This appliance needs fresh air for safe operation and must be installed so there are provisions for adequate combustion and ventilation air.

If not installed, operated, and maintained in accordance with the manufacturer's instructions, this product could expose you to substances in fuel or fuel combustion which are known to the State of California to cause cancer, birth defects, or other reproductive harm.

Keep burner and control compartment clean. See installation and operating instructions accompanying appliance.

For additional information on operating your  
Hearth & Home Technologies fireplace, please refer to [www.fireplaces.com](http://www.fireplaces.com).

### CAUTION:

Hot while in operation. **DO NOT** touch. Keep children, clothing, furniture, gasoline and other liquids having flammable vapors away.

**DO NOT** operate the appliance with fixed glass assembly removed, cracked or broken. Replacement of the fixed glass assembly should be done by a licensed or qualified service person.

### NOT FOR USE WITH SOLID FUEL

For use with natural gas and propane. A conversion kit, as supplied by the manufacturer, shall be used to convert this appliance to the alternate fuel.

**Also Certified for Installation in a Bedroom or a Bedsitting Room.**

For assistance or additional information, consult a qualified installer, service agency or the gas supplier.

### LIGHTING INSTRUCTIONS (IPI)

1. This appliance is equipped with an ignition device which automatically lights the burner. **DO NOT** try to light the burner by hand.

**GAS  
VALVE**

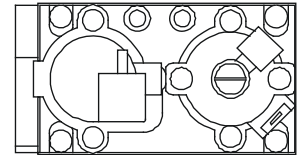

2. Wait five (5) minutes to clear out any gas. Then smell for gas, including near the floor. If you smell gas, **STOP!** Follow "B" in the Safety Information located on the left side of this label. If you do not smell gas, go to next step.
3. To light the burner:  
Equipped with wall switch: Turn ON/OFF switch to ON.  
Equipped with remote or wall control: Press ON or FLAME button.  
Equipped with thermostat: Set temperature to desired setting.
4. If the appliance does not light after three tries, call your service technician or gas supplier.

### TO TURN OFF GAS TO APPLIANCE

1. Equipped with wall switch: Turn ON/OFF switch to OFF.  
Equipped with remote or wall control: Press OFF button.  
Equipped with thermostat: Set temperature to lowest setting.
2. Service technician should turn off electric power to the control when performing service.

593-913G

Final inspection by \_\_\_\_\_

## J. After Fireplace is Lit

### Initial Break-in Procedure

- The fireplace should be run three to four hours continuously on high.
- Turn the fireplace off and allow it to completely cool.
- Remove fixed glass assembly. See Section 14.G.
- Clean fixed glass assembly. See Section 3.
- Replace the fixed glass assembly and run continuously on high an additional 12 hours.

This cures the materials used to manufacture the fireplace.

**NOTICE! Open windows for air circulation during fireplace break-in.**

- *Some people may be sensitive to smoke and odors.*
- *Smoke detectors may activate.*

## K. Frequently Asked Questions

ISSUE	SOLUTIONS
Condensation on the glass	This is a result of gas combustion and temperature variations. As the fireplace warms, this condensation will disappear.
Blue flames	This is a result of normal operation and the flames will begin to yellow as the fireplace is allowed to burn for 20 to 40 minutes.
Odor from fireplace	When first operated, this fireplace may release an odor for the first several hours. This is caused by the curing of materials from manufacturing. Odor may also be released from finishing materials and adhesives used near the fireplace. These circumstances may require additional curing related to the installation environment.
Film on the glass	This is a normal result of the curing process of the paint and logs. Glass should be cleaned within 3 to 4 hours of initial burning. A non-abrasive cleaner such as gas fireplace glass cleaner may be necessary. See your dealer.
Metallic noise	Noise is caused by metal expanding and contracting as it heats up and cools down, similar to the sound produced by a furnace or heating duct. This noise does not affect the operation or longevity of the fireplace.

# 3 Maintenance and Service

Any safety screen or guard removed for servicing must be replaced prior to operating the fireplace.

When properly maintained, your fireplace will give you many years of trouble-free service. We recommend annual service by a qualified service technician.

## A. Maintenance Tasks-Homeowner

Installation and repair should be done by a qualified service technician only. The fireplace should be inspected before use and at least annually by a professional service person.

The following tasks may be performed annually by the homeowner. If you are uncomfortable performing any of the listed tasks, please call your dealer for a service appointment.

More frequent cleaning may be required due to lint from carpeting or other factors. Control compartment, burner and circulating air passageway of the fireplace must be kept clean.

**CAUTION! Risk of Burns!** *The fireplace should be turned off and cooled before servicing.*

### Glass Cleaning

**Frequency:** Seasonally

**By:** Homeowner

**Tools Needed:** Protective gloves, glass cleaner, drop cloth and a stable work surface.

**CAUTION! Handle fixed glass assembly with care.** *Glass is breakable.*

- Avoid striking, scratching or slamming glass
- Avoid abrasive cleaners
- **DO NOT** clean glass while it is hot
- Prepare a work area large enough to accommodate fixed glass assembly and door frame by placing a drop cloth on a flat, stable surface.

**Note:** Fixed glass assembly and gasketing may have residue that can stain carpeting or floor surfaces.

- Remove door or decorative front from fireplace and set aside on work surface.
- See Section 14.G for instructions to remove fixed glass assembly.
- Clean glass with a non-abrasive commercially available cleaner.
  - Light deposits: Use a soft cloth with soap and water
  - Heavy deposits: Use commercial fireplace glass cleaner (consult with your dealer)
- Carefully set fixed glass assembly in place on fireplace. Hold glass in place with one hand and secure glass latches with the other hand.
- Reinstall door or decorative front.

### Doors, Surrounds, Fronts

**Frequency:** Annually

**By:** Homeowner

**Tools needed:** Protective gloves, stable work surface

- Assess condition of screen and replace as necessary.
- Inspect for scratches, dents or other damage and repair as necessary.
- Check that louvers are not blocked.
- Vacuum and dust surfaces.

### Remote Control

**Frequency:** Seasonally

**By:** Homeowner

**Tools needed:** Replacement batteries and remote control instructions.

- Locate remote control transmitter and receiver.
- Verify operation of remote. Refer to remote control operation instructions for proper calibration and setup procedure.
- Place batteries as needed in remote transmitters and battery-powered receivers.
- Place remote control out of reach of children.

If not using your fireplace for an extended period of time (summer months, vacations/trips, etc), to prevent unintended operation:

- Remove batteries from remote controls.
- Unplug 3 volt adapter plug on IPI models.

### Venting

**Frequency:** Seasonally

**By:** Homeowner

**Tools needed:** Protective gloves and safety glasses.

- Inspect venting and termination cap for blockage or obstruction such plants, bird nests, leaves, snow, debris, etc.
- Verify termination cap clearance to subsequent construction (building additions, decks, fences, or sheds). See Section 6.
- Inspect for corrosion or separation.
- Verify weather stripping, sealing and flashing remains intact.
- Inspect draft shield to verify it is not damaged or missing.



## Ember Light Replacement

**Frequency:** As Required

**By:** Homeowner or Qualified Service Technician

**Tools needed:** Protective gloves, 5/16 in. nut driver

In the lower gas valve compartment you will find three access panels for the three light bulbs. See Figure 3.1



**Figure 3.1** Access Panel

1. Unplug the electrical cord as shown Figure 13.1.
2. Remove the two bolts using a 5/16 in. nut driver. See Figure 3.2.



**Figure 3.2** Remove Bolts

3. Pull the access panel to expose the light bulb. Wearing clean cotton gloves, replace the bulb. Any skin oils which get on a new bulb will greatly reduce the life of the bulb. The bulb can be cleaned with isopropyl alcohol. See Figure 3.3.

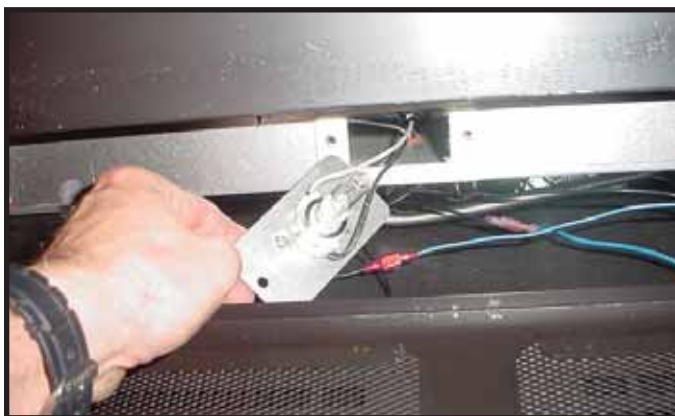

**Figure 3.3** Replace Bulb

## B. Maintenance Tasks-Qualified Service Technician

The following tasks must be performed by a qualified service technician.

### Gasket Seal and Glass Assembly Inspection

**Frequency:** Annually

**By:** Qualified Service Technician

**Tools needed:** Protective gloves, drop cloth and a stable work surface.

- Inspect gasket seal and its condition.
- Inspect fixed glass assembly for scratches and nicks that can lead to breakage when exposed to heat.
- Confirm there is no damage to glass or glass frame. Replace as necessary.
- Verify that fixed glass assembly is properly retained and attachment components are intact and not damaged. Replace as necessary.

### Logs

**Frequency:** Annually

**By:** Qualified Service Technician

**Tools needed:** Protective gloves.

- Inspect for damaged or missing logs. Replace as necessary. Refer to Section 14 for log placement instructions.
- Verify correct log placement and no flame impingement causing sooting. Correct as necessary.

### Firebox

**Frequency:** Annually

**By:** Qualified Service Technician

**Tools needed:** Protective gloves, sandpaper, steel wool, cloths, mineral spirits, primer and touch-up paint.

- Inspect for paint condition, warped surfaces, corrosion or perforation. Sand and repaint as necessary.
- Replace fireplace if firebox has been perforated.

### Control Compartment and Firebox Top

**Frequency:** Annually

**By:** Qualified Service Technician

**Tools needed:** Protective gloves, vacuum cleaner, dust cloths

- Vacuum and wipe out dust, cobwebs, debris or pet hair. Use caution when cleaning these areas. Screw tips that have penetrated the sheet metal are sharp and should be avoided.
- Remove all foreign objects.
- Verify unobstructed air circulation.

## Burner Ignition and Operation

**Frequency:** Annually

**By:** Qualified Service Technician

**Tools needed:** Protective gloves, vacuum cleaner, whisk broom, flashlight, voltmeter, indexed drill bit set, and a manometer.

- Verify burner is properly secured and aligned with pilot or igniter.
  - Clean off burner top, inspect for plugged ports, corrosion or deterioration. Replace burner if necessary.
  - Replace ember materials with new dime-size pieces. **DO NOT** block ports or obstruct lighting paths. Refer to Section 14 for proper ember placement.
  - Verify batteries have been removed from battery back-up IPI systems to prevent premature battery failure or leaking.
  - Check for smooth lighting and ignition carryover to all ports. Verify that there is no ignition delay.
  - Inspect for lifting or other flame problems.
  - Verify air shutter setting is correct. See Section 14 for required air shutter setting. Verify air shutter is clear of dust and debris.
  - Inspect orifice for soot, dirt and corrosion. Verify orifice size is correct. See Service Parts List for proper orifice sizing.
  - Verify manifold and inlet pressures. Adjust regulator as required.
  - Inspect pilot flame pattern and strength. See Figure 3.4 for proper pilot flame pattern. Clean or replace orifice spud as necessary.
  - Inspect IPI flame-sensing rod for soot, corrosion and deterioration. Polish with fine steel wool or replace as required.
- 
- Verify that there is not a short in flame sense circuit by checking continuity between pilot hood and flame-sensing rod. Replace pilot as necessary.

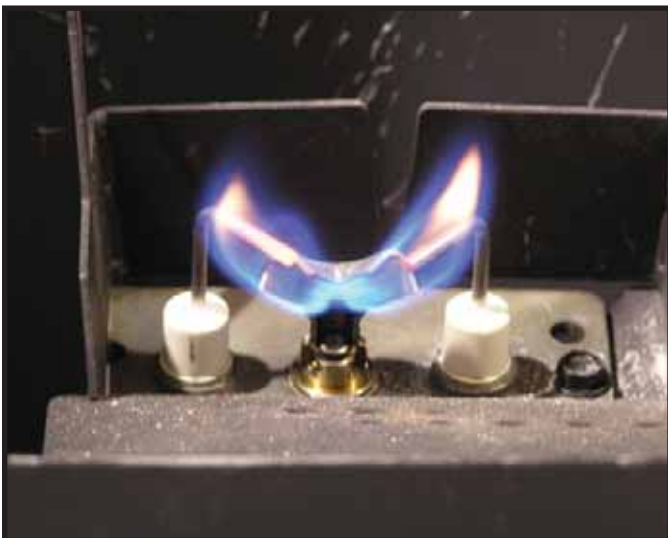

Figure 3.4 IPI Pilot Flame Patterns

# 4 Getting Started

# Installer Guide

## A. Typical Appliance System

**NOTICE:** Illustrations and photos reflect typical installations and are for design purposes only. Illustrations/diagrams are not drawn to scale. Actual product may vary from pictures in manual

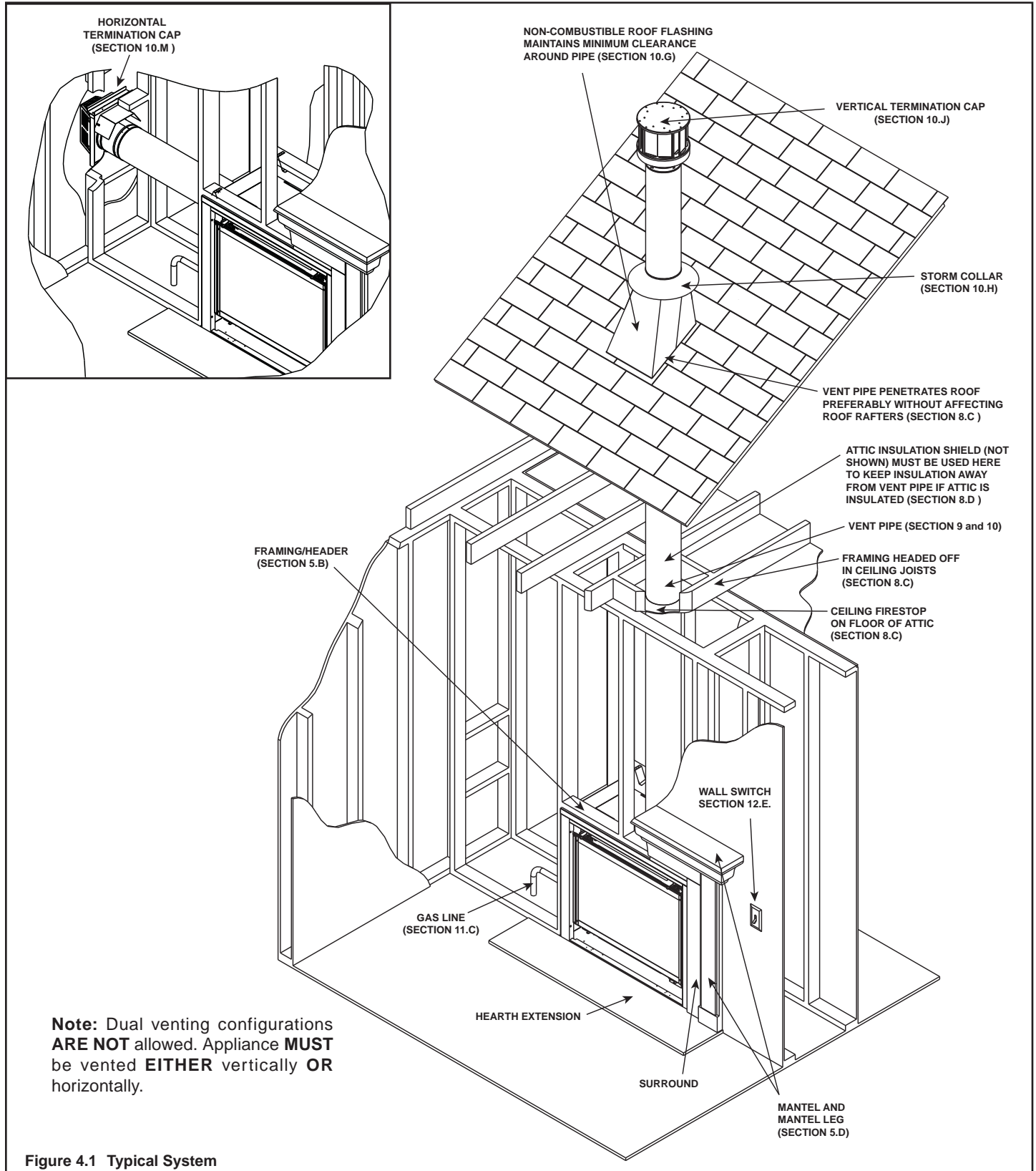

## B. Design and Installation Considerations

Heat & Glo direct vent gas appliances are designed to operate with all combustion air siphoned from outside of the building and all exhaust gases expelled to the outside. No additional outside air source is required.

Installation **MUST** comply with local, regional, state and national codes and regulations. Consult insurance carrier, local building inspector, fire officials or authorities having jurisdiction over restrictions, installation inspection and permits.

Before installing, determine the following:

- Where the appliance is to be installed.
- The vent system configuration to be used.
- Gas supply piping.
- Electrical wiring requirements.
- Framing and finishing details.
- Whether optional accessories—devices such as a fan, wall switch, or remote control—are desired.

Improper installation, adjustment, alteration, service or maintenance can cause injury or property damage. For assistance or additional information, consult a qualified service technician, service agency or your dealer.

## C. Tools and Supplies Needed

Before beginning the installation be sure that the following tools and building supplies are available.

Tape measure	Framing material
Pliers	Non-corrosive leak check solution
Hammer	Phillips screwdriver
Gloves	Framing square
Voltmeter	Electric drill and bits (1/4 in.)
Plumb line	Safety glasses
Level	Reciprocating saw
Manometer	Flat blade screwdriver
1/2 - 3/4 in. length, #6 or #8 Self-drilling screws	
Caulk (minimum of 300°F continuous exposure rating)	
One 1/4 in. female connection (for optional fan).	

## D. Inspect Appliance and Components

- Carefully remove the appliance and components from the packaging.
- The vent system components and decorative doors and fronts may be shipped in separate packages.
- If packaged separately, the log set and appliance grate must be installed.
- Report to your dealer any parts damaged in shipment, particularly the condition of the glass.
- **Read all of the instructions before starting the installation. Follow these instructions carefully during the installation to ensure maximum safety and benefit.**

**WARNING! Risk of Fire or Explosion!** Damaged parts could impair safe operation. **DO NOT** install damaged, incomplete or substitute components. Keep appliance dry.

Hearth & Home Technologies disclaims any responsibility for, and the warranty will be voided by, the following actions:

- Installation and use of any damaged appliance or vent system component.
- Modification of the appliance or vent system.
- Installation other than as instructed by Hearth & Home Technologies.
- Improper positioning of the gas logs or the glass door.
- Installation and/or use of any component part not approved by Hearth & Home Technologies.

**Any such action may cause a fire hazard.**

**WARNING! Risk of Fire, Explosion or Electric Shock!** **DO NOT** use this appliance if any part has been under water. Call a qualified service technician to inspect the appliance and to replace any part of the control system and/or gas control which has been under water.

# 5 Framing and Clearances

## A. Selecting Appliance Location

When selecting a location for the appliance it is important to consider the required clearances to walls (see Figure 5.1).

**WARNING! Risk of Fire or Burns!** Provide adequate clearance around air openings and for service access. Due to high temperatures, the appliance should be located out of traffic and away from furniture and draperies.

**NOTICE:** Illustrations reflect typical installations and are FOR DESIGN PURPOSES ONLY. Illustrations/diagrams are not drawn to scale. Actual installation may vary due to individual design preference.

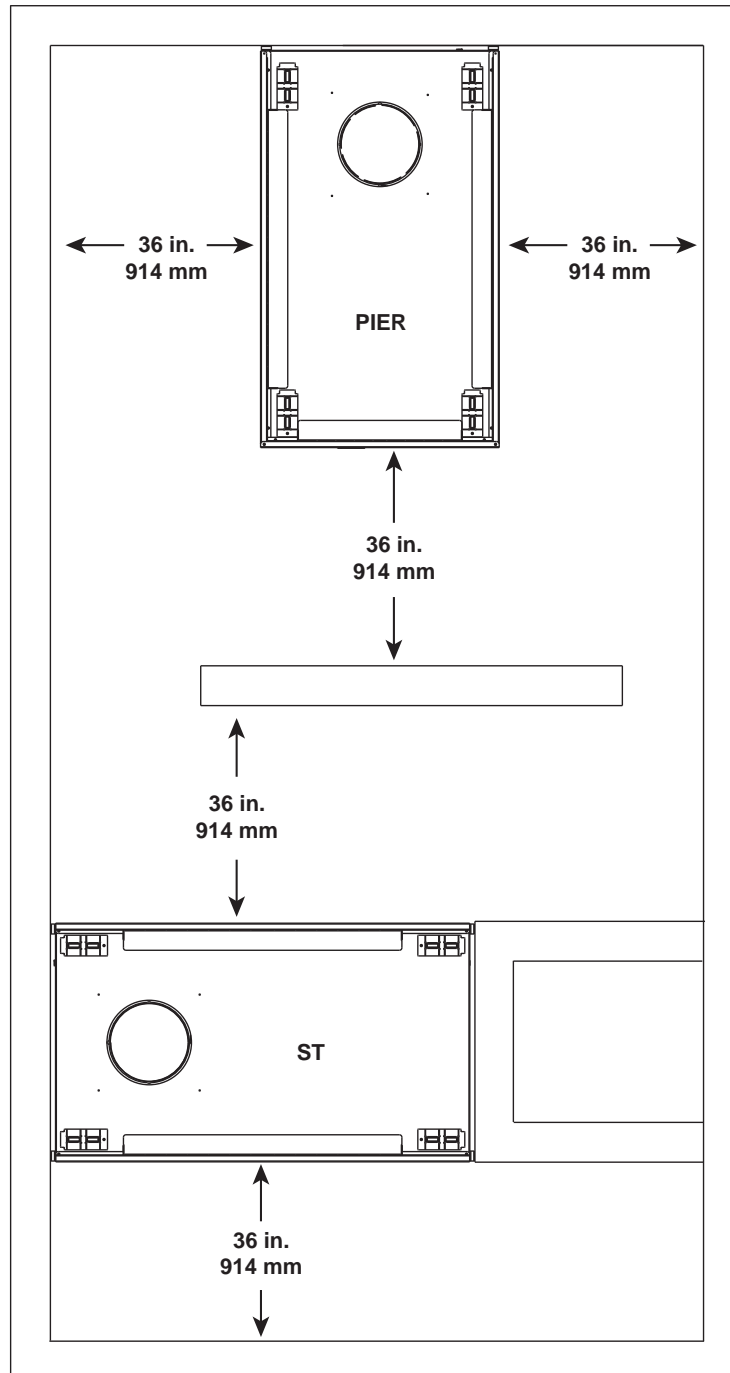

Figure 5.1 Appliance Locations



## B. Constructing the Appliance Chase

A chase is a vertical box-like structure built to enclose the gas appliance and/or its vent system. In cooler climates the vent should be enclosed inside the chase.

**NOTICE:** Treatment of ceiling firestops and wall shield firestops and construction of the chase may vary with the type of building. These instructions are not substitutes for the requirements of local building codes. Therefore, you **MUST** check local building codes to determine the requirements to these steps.

Chases should be constructed in the manner of all outside walls of the home to prevent cold air drafting problems. The chase should not break the outside building envelope in any manner.

Walls, ceiling, base plate and cantilever floor of the chase should be insulated. Vapor and air infiltration barriers should be installed in the chase as per regional codes for the rest of the home. Additionally, in regions where cold air infiltration may be an issue, the inside surfaces may be sheetrocked and taped for maximum air tightness.

To further prevent drafts, the wall shield and ceiling firestops should be caulked with caulk with a minimum of

300°F continuous exposure rating to seal gaps. Gas line holes and other openings should be caulked with caulk with a minimum of 300°F continuous exposure rating or stuffed with unfaced insulation. If the appliance is being installed on a cement slab, a layer of plywood may be placed underneath to prevent conducting cold up into the room.

## C. Clearances

**NOTICE:** Install appliance on hard metal or wood surfaces extending full width and depth. **DO NOT** install directly on carpeting, vinyl, tile or any combustible material other than wood.

**WARNING! Risk of Fire!** Maintain specified air space clearances to appliance and vent pipe:

- Insulation and other materials must be secured to prevent accidental contact.
- The chase must be properly blocked to prevent blown insulation or other combustibles from entering and making contact with fireplace or chimney.
- Failure to maintain airspace may cause overheating and a fire.

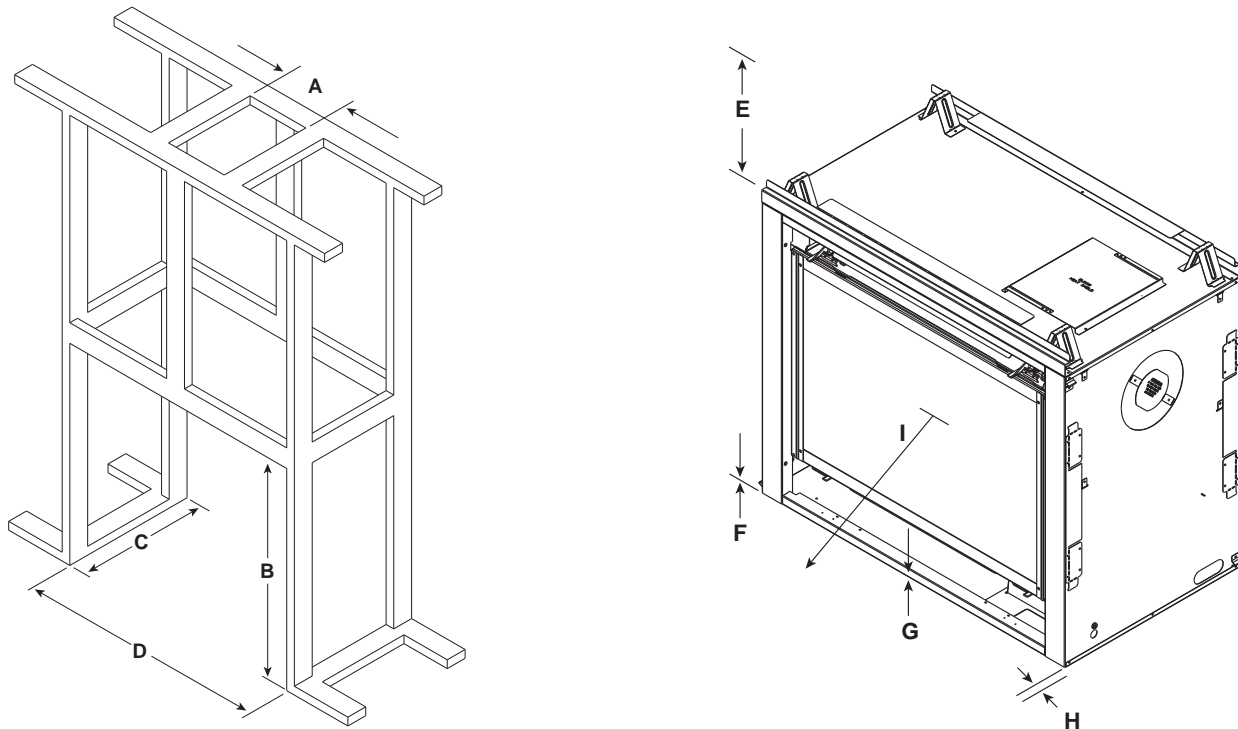

ST-36TR-IPI	A		B	C	D	E	F	G	H	I
	DVP Pipe	SLP Pipe	Rough Opening (Height)	DVP Pipe*	Rough Opening (Width)	Clearance to Ceiling	Combustible Floor	Combustible Flooring	Ends of Appliance	Sides of Appliance
	Rough Opening (Width)	Rough Opening (Width)		Rough Opening (Depth)						
Inches	10	9	38-1/8	23	43	29-1/2	0	0	1/2	36
Millimeters	254	229	968	584	1092	749	0	0	13	914

\* Adjust framing dimensions for interior sheathing (such as sheetrock)

Figure 5.2 Clearances to Combustibles ST-36TR-IPI

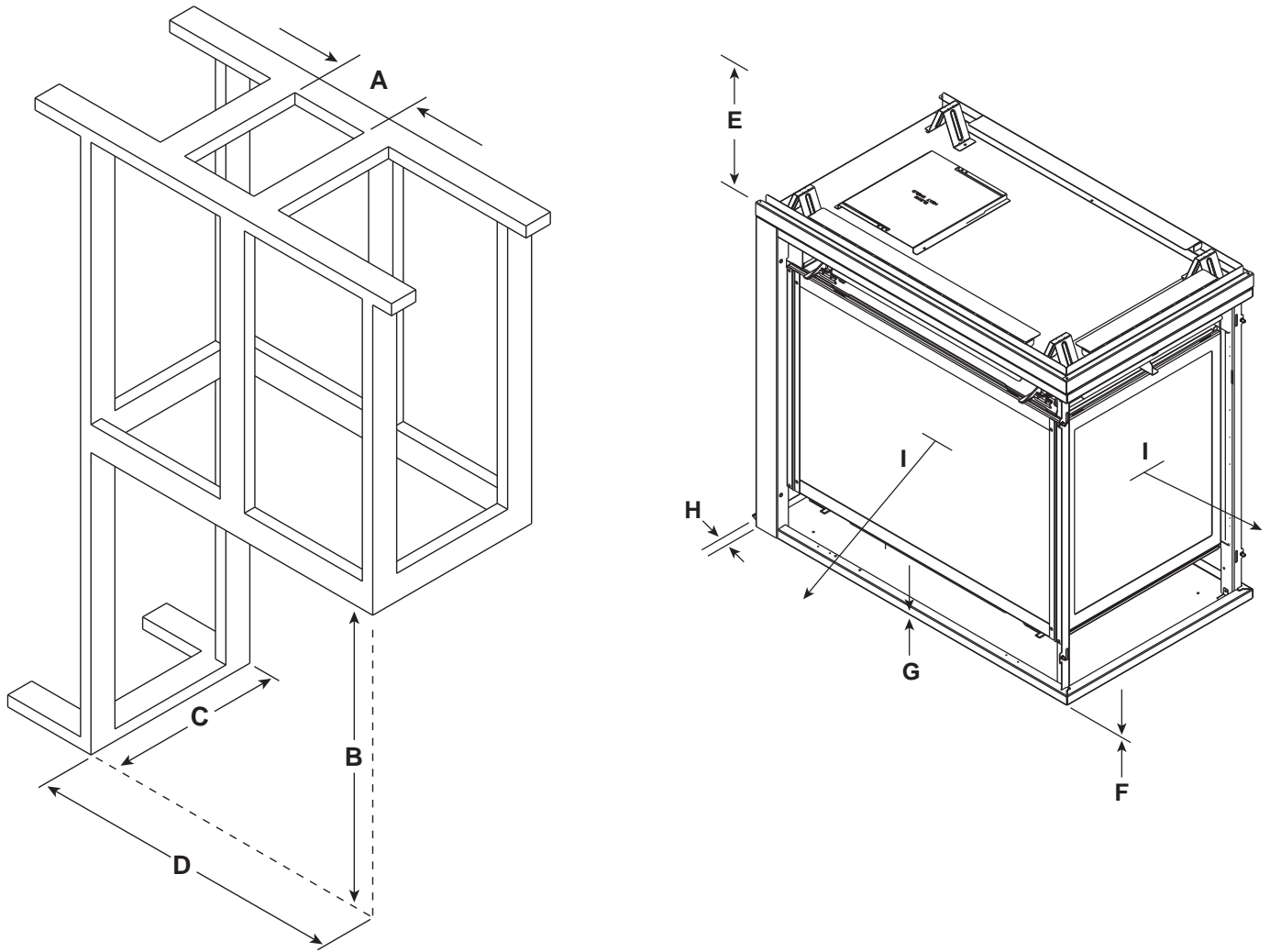

PIER-36TR-IPI	A		B	C	D	E	F	G	H	I
	DVP Pipe	SLP Pipe	Rough Opening (Height)	DVP Pipe*	Rough Opening (Width)	Clearance to Ceiling	Combustible Floor	Combustible Flooring	Ends of Appliance	Sides of Appliance
	Rough Opening (Width)	Rough Opening (Width)		Rough Opening (Depth)						
Inches	10	8-5/8	38-1/8	23	40	31-5/8	0	0	1/2	36
Millimeters	254	219	968	584	1046	803	0	0	13	914

\* Adjust framing dimensions for interior sheathing (such as sheetrock)

Figure 5.3 Clearances to Combustibles PIER-36TR-IPI

## D. Mantel and Wall Projections

**WARNING! Risk of Fire!** Comply with all minimum clearances as specified. Framing or finishing material closer than the minimums listed must be constructed entirely of noncombustible materials (i.e., steel studs, concrete board, etc).

### See-Through Combustible Mantel

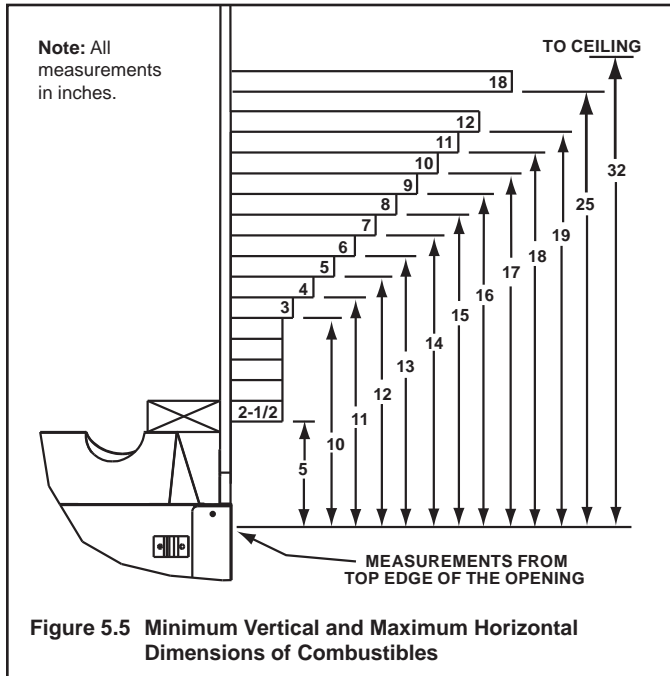

### See-Through Non-Combustible Mantel

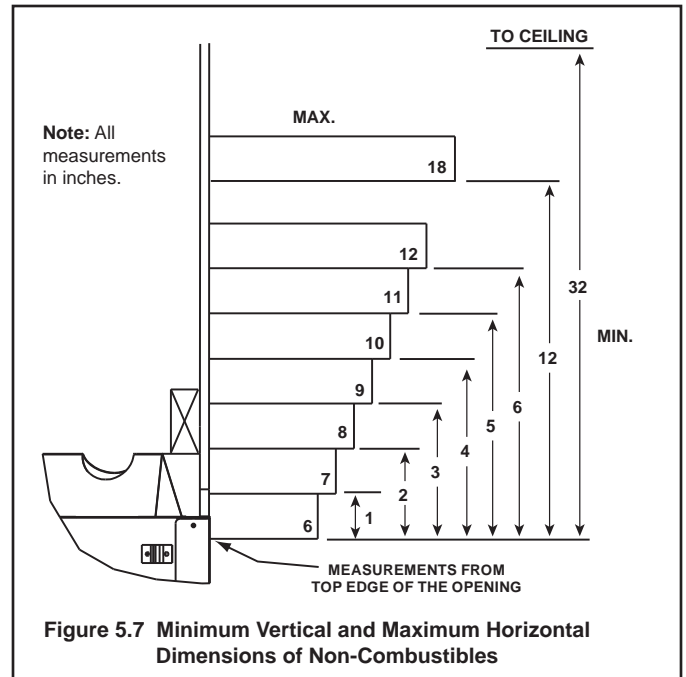

### PIER Combustible Mantel

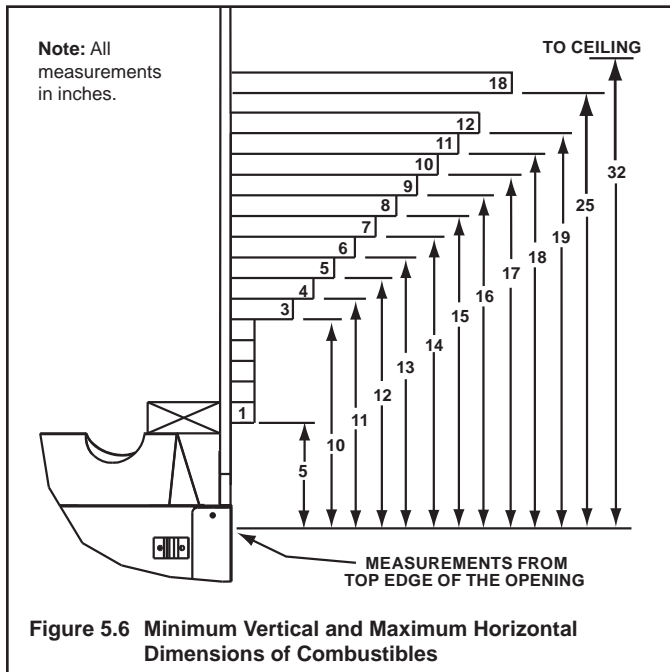

### PIER Non-Combustible Mantel

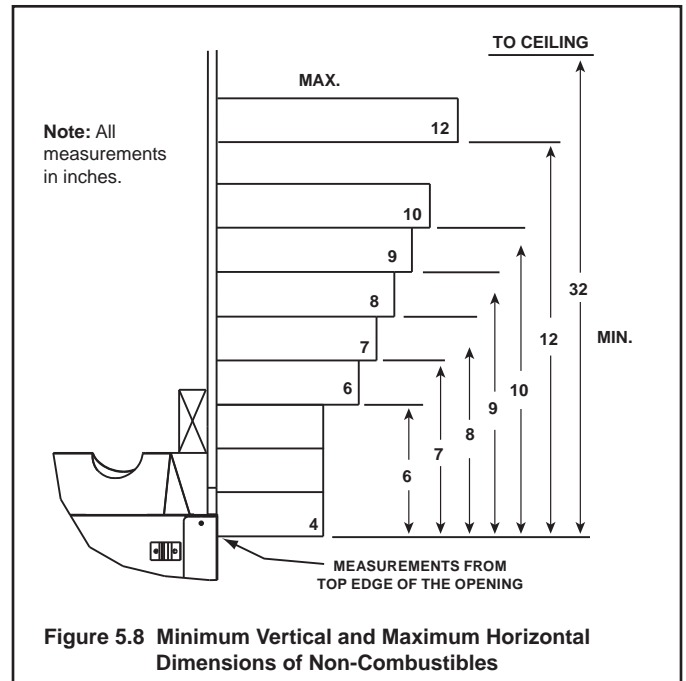

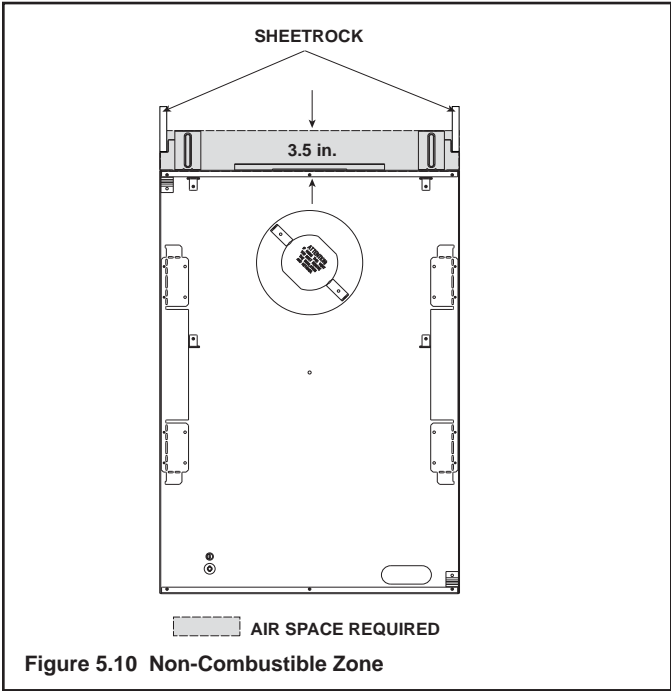
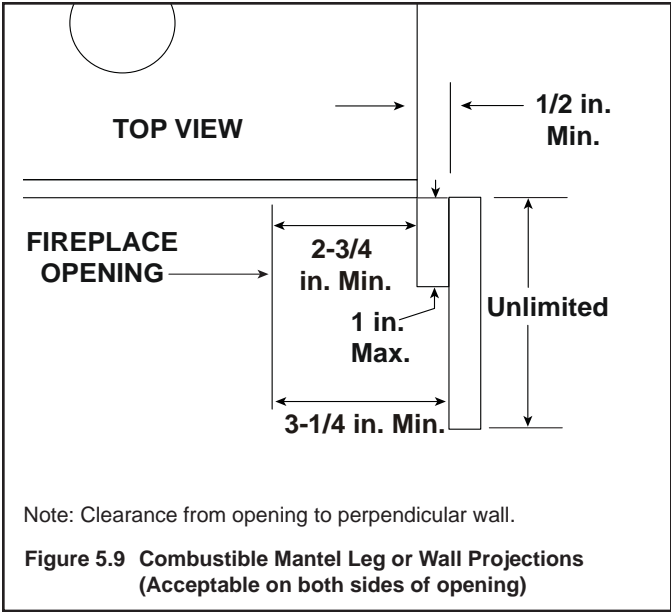

# 6 Termination Locations

## A. Vent Termination Minimum Clearances



**WARNING**

Fire Risk.  
Maintain vent clearance to combustibles as specified.

- **DO NOT** pack air space with insulation or other materials.

Failure to keep insulation or other materials away from vent pipe may cause overheating and fire.

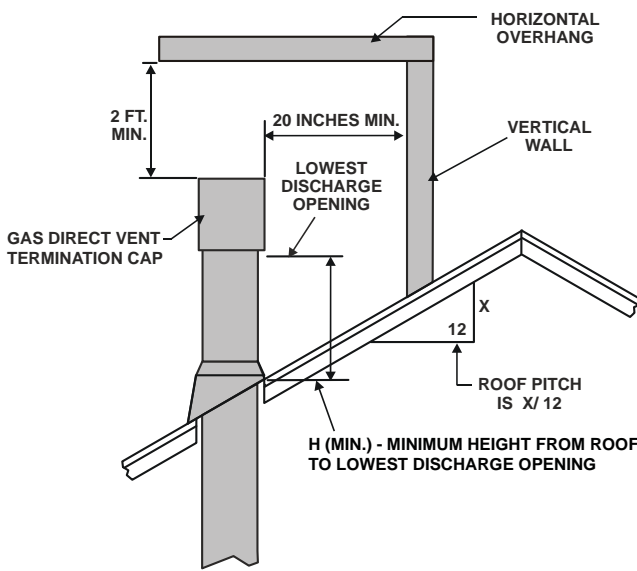

Roof Pitch	H (Min.) Ft.
Flat to 6/12.....	1.0*
Over 6/12 to 7/12.....	1.25*
Over 7/12 to 8/12.....	1.5*
Over 8/12 to 9/12.....	2.0*
Over 9/12 to 10/12.....	2.5*
Over 10/12 to 11/12.....	3.25
Over 11/12 to 12/12.....	4.0
Over 12/12 to 14/12.....	5.0
Over 14/12 to 16/12.....	6.0
Over 16/12 to 18/12.....	7.0
Over 18/12 to 20/12.....	7.5
Over 20/12 to 21/12.....	8.0

\* 3 foot minimum in snow regions

**Figure 6.1 Minimum Height From Roof To Lowest Discharge Opening**

A	B
6 in. (minimum) up to 20 in. 152 mm/508 mm	18 in. minimum 457 mm
20 in. and over	0 in. minimum

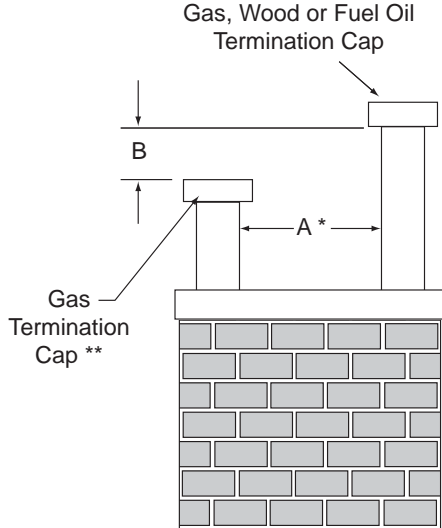

\* If using decorative cap cover(s), this distance may need to be increased. Refer to the installation instructions supplied with the decorative cap cover.

\*\* In a staggered installation with both gas and wood or fuel oil terminations, the wood or fuel oil termination cap must be higher than the gas termination cap.

**Figure 6.2 Staggered Termination Caps**



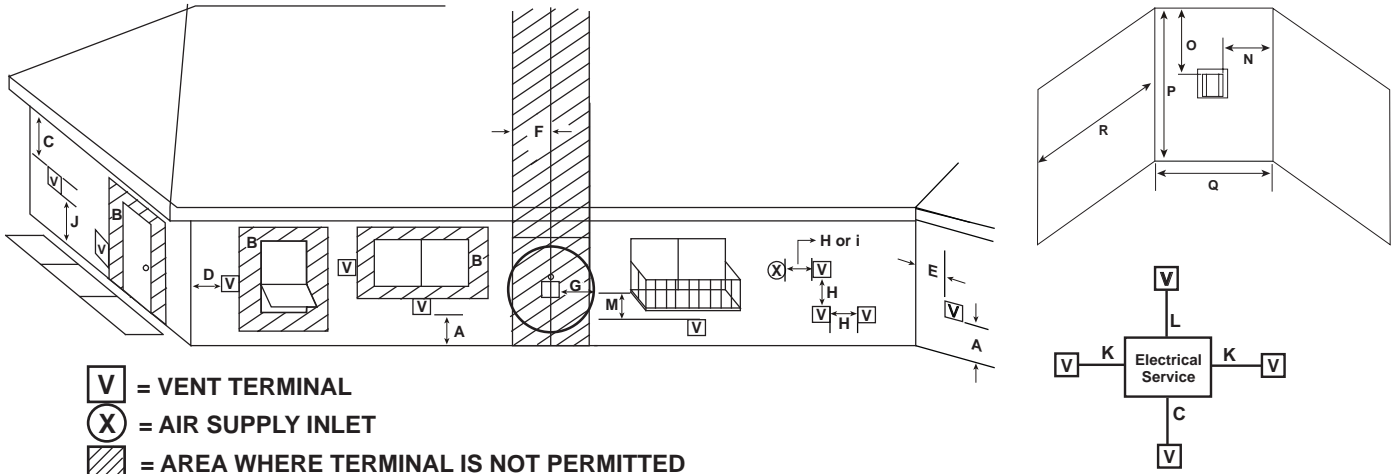

- V** = VENT TERMINAL  
**X** = AIR SUPPLY INLET  
 [Hatched] = AREA WHERE TERMINAL IS NOT PERMITTED
- A = 12 inches.....clearances above grade, veranda, porch, deck or balcony
  - B = 12 inches.....clearance to window or door that may be opened, or to permanently closed window
  - C = 18 inches.....clearance below unventilated soffit  
 18 inches.....clearance below ventilated soffit  
 30 inches.....clearance below vinyl soffits and electrical service
  - D = 9 inches.....clearance to outside corner
  - E = 6 inches.....clearance to inside corner
  - F = 3 ft. (Canada).....not to be installed above a gas meter/regulator assembly within 3 feet horizontally from the center-line of the regulator
  - G = 3 ft.....clearance to gas service regulator vent outlet
  - H = 9 inches (U.S.A)  
 12 inches (Canada) .clearance to non-mechanical (unpowered) air supply inlet, combustion air inlet or direct-vent termination
  - i = 3 ft. (U.S.A.)  
 6 ft. (Canada).....clearance to a mechanical (powered) air supply inlet

All mechanical air intakes within 10 feet of a termination cap must be a minimum of 3 feet below termination.

J = 7 ft. .... On **public** property: clearance above paved sidewalk or a paved driveway.

A vent shall not terminate directly above a sidewalk or paved driveway which is located between two single family dwellings and serves both dwellings.

- K = 6 inches.....clearance from sides of electrical service
- L = 12 inches.....clearance above electrical service  
 Location of the vent termination must not interfere with access to the electrical service.

M = 18 inches ..... clearance under veranda, porch, deck, balcony or overhang  
 42 inches .....vinyl or composite overhang  
 Permitted when veranda, porch, deck or balcony is fully open on a minimum of 2 sides beneath the floor.

**Covered Above Applications**  
 (Spaces open only on one side and with an overhang)

- N = 6 inches ..... non-vinyl sidewalls  
 12 inches ..... vinyl sidewalls
- O = 18 inches ..... non-vinyl soffit and overhang  
 42 inches ..... vinyl soffit and overhang
- P = 8 ft.

	Q <sub>MIN</sub>	R <sub>MAX</sub>
1 cap	3 feet	2 x Q <sub>ACTUAL</sub>
2 caps	6 feet	1 x Q <sub>ACTUAL</sub>
3 caps	9 feet	2/3 x Q <sub>ACTUAL</sub>
4 caps	12 feet	1/2 x Q <sub>ACTUAL</sub>

Q<sub>MIN</sub> = # termination caps x 3    R<sub>MAX</sub> = (2 / # termination caps) x Q<sub>ACTUAL</sub>

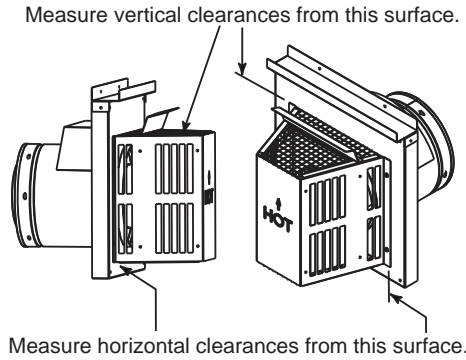

**CAUTION! Risk of Burns!** Termination caps are **HOT**, consider proximity to doors, traffic areas or where people may pass or gather (sidewalk, deck, patio, etc.). Listed cap shields available. Contact your dealer.

- Local codes or regulations may require different clearances.
- Vent system termination is **NOT** permitted in screened porches.
- Vent system termination is permitted in porch areas with two or more sides open.
- Hearth & Home Technologies assumes no responsibility for the improper performance of the appliance when the venting system does not meet these requirements.
- Vinyl protection kits are suggested for use with vinyl siding.

➔ **Figure 6.3 Minimum Clearances for Termination**

## B. Continue Adding Vent Components

**WARNING! Risk of Fire!** Installation of this appliance may require the use of heat shield 385-920 above the first 90° elbow in the venting system.

### To Install the Heat Shield:

1. Determine if the heat shield is required. Do so by measuring the vertical distance between the top horizontal surface of the elbow to any combustible surface above. If the distance is more than 4 inches, the heat shield is **NOT** required. If it is 4 inches or less, the heat shield **IS REQUIRED**. Install per the following steps. See Figure 6.4.

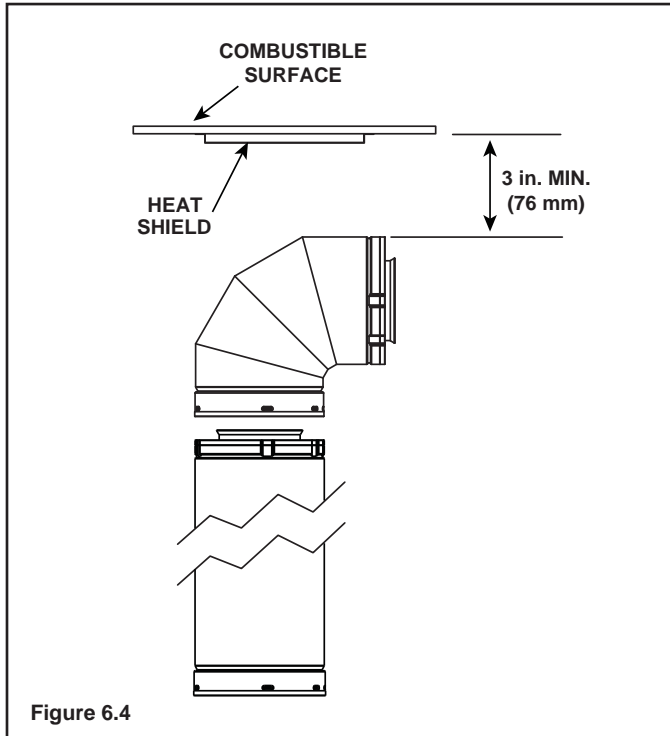

2. Fasten the shield in place using the four pilot holes provided in the part. The shield should be oriented such that the 13-1/8 inch dimension (longest dimension) is running in the same direction the elbow is pointing. The shield should be centered directly above the elbow, and positioned so that it creates a 1/2 inch airspace between the shield and the combustible surface. See Figure 6.5.

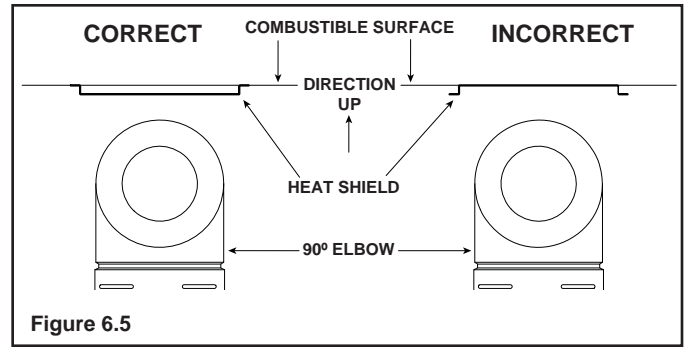

- If the combustible materials are not in place at the time of install the elbow heat shield may be screwed to the exhaust pipe (see Figure 6.6). Cut the tabs as shown and bend down. Secure the heat shield to the pipe maintaining 3 inch to 4 inch between the pipe and shield.

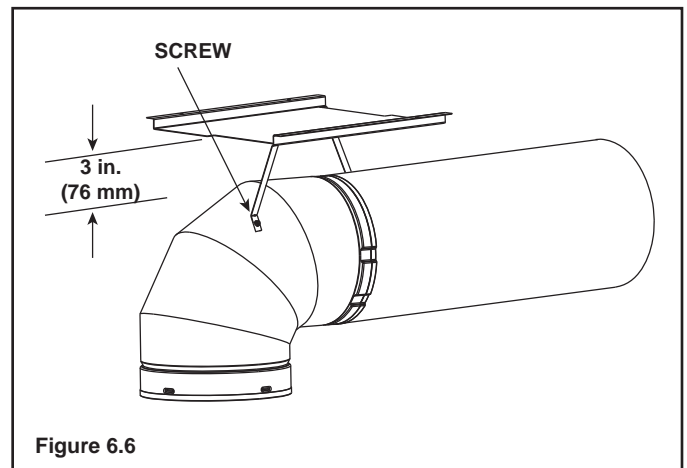

Refer to DVP Pipe and Termination Cap installation instructions.

- Continue adding vent components, locking each succeeding component into place.
- Ensure that each succeeding vent component is securely fitted and locked into the preceding component in the vent system.
- 90° elbows may be installed and rotated to any point around the preceding component's vertical axis. If an elbow does not end up in a locked position with the preceding component, attach with a minimum of two (2) sheet metal screws.

## C. Install Support Brackets

Refer to cinch pipe and termination cap installation instructions.

# 7 Vent Information and Diagrams

## A. Approved Pipe

This appliance is approved for use with Hearth & Home Technologies a DVP venting system. Refer to Section 16B for vent component information.

**DO NOT** mix pipe, fittings or joining methods from different manufacturers.

The pipe is tested to be run inside an enclosed wall. There is no requirement for inspection openings at each joint within the wall.

**WARNING! Risk of Fire or Asphyxiation.** This appliance requires a separate vent. **DO NOT** vent to a pipe serving a separate solid fuel burning appliance.

## B. Vent Table Key

The abbreviations listed in this vent table key are used in the vent diagrams.

Symbol	Description
V <sub>1</sub>	First section (closest to appliance) of vertical length
V <sub>2</sub>	Second section of vertical length
H <sub>1</sub>	First section (closest to appliance) of horizontal length
H <sub>2</sub>	Subsequent sections of horizontal length

## C. Use of Elbows

Diagonal runs have both vertical and horizontal vent aspects when calculating the effects. Use the rise for the vertical aspect and the run for the horizontal aspect (see Figure 7.1).

Two 45° elbows may be used in place of one 90° elbow. On 45° runs, one foot of diagonal is equal to 8-1/2 in. (216 mm) horizontal run and 8-1/2 in. (216 mm) vertical run. A length of straight pipe is allowed between two 45° elbows (see Figure 7.1).

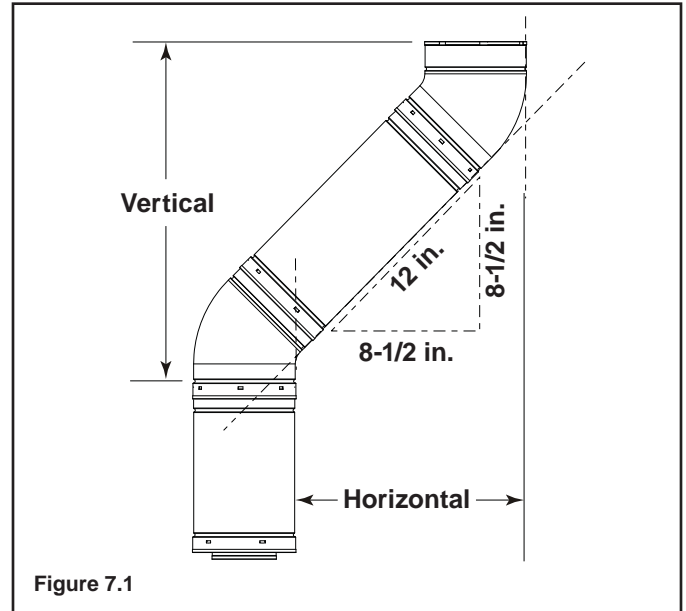

Figure 7.1

## D. Measuring Standards

Vertical and horizontal measurements listed in the vent diagrams were made using the following standards.

- Pipe measurements are shown using the effective length of pipe (see Figure 7.2).
- Horizontal terminations are measured to the outside mounting surface (flange of termination cap) (see Figure 6.1).
- Vertical terminations are measured to bottom of termination cap.
- Horizontal pipe installed level with no rise.

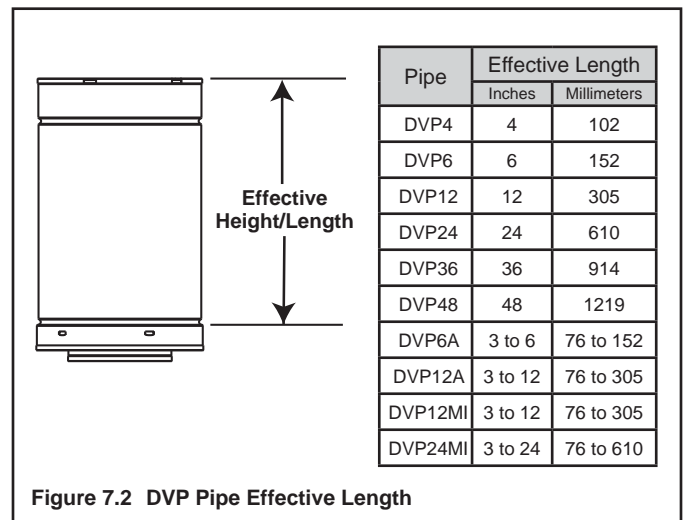

Figure 7.2 DVP Pipe Effective Length

## E. Vent Diagrams

To replace the first starter elbow with two 45° elbows, refer to Figure 7.3. All other 90° elbows can be replaced with two 45° elbows.

General Rules:

- A maximum of three 90° elbows (or six 45° elbows) may be used in any vent configuration. Some elbows may be installed horizontally. See Figure 7.6.
- Elbows may be placed back to back anywhere in the system as long as the first 90° elbow is a starter elbow except as shown in Figure 7.3.
- When penetrating a combustable wall, a wall shield firestop must be installed.
- When penetrating a combustable ceiling, a ceiling firestop must be installed.
- Horizontal runs of vent do not require vertical rise; horizontal runs may be level.

**Note: The Multi-Sided series fireplaces can adapt to SLP series vent pipe, if desired.**

When venting off the top of the unit, attach a DVP-2SL adapter to the appliance starting collar, immediately followed by a minimum 48 inch vertical section of SLP series vent pipe.

**After** the 48 inch vertical section, the venting table rules must be followed. The first 48 inch vertical section is NOT counted as part of the **vertical** components in the table. It is still counted as part of the overall maximum run. All venting table rules for the vent run must still be followed.

**Example:** DVP pipe 3 ft. min. vertical = 11 ft. max. horizontal  
SLP pipe 7 ft. min. vertical = 11 ft. max. horizontal

### 1. Top Vent - Horizontal Termination - (continued)

Top Vent—Horizontal Termination—Two 45° Elbows

Installation requirements to replace the first 90° elbow with two 45° elbows:

**Note:** Reference Figure 7.14 for special instructions for use of 45° elbow on rear vent appliances.

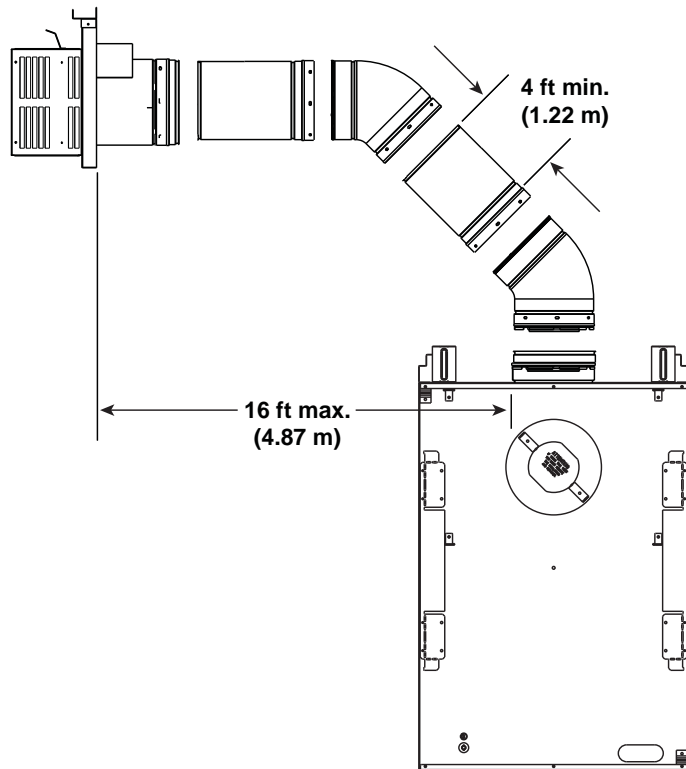
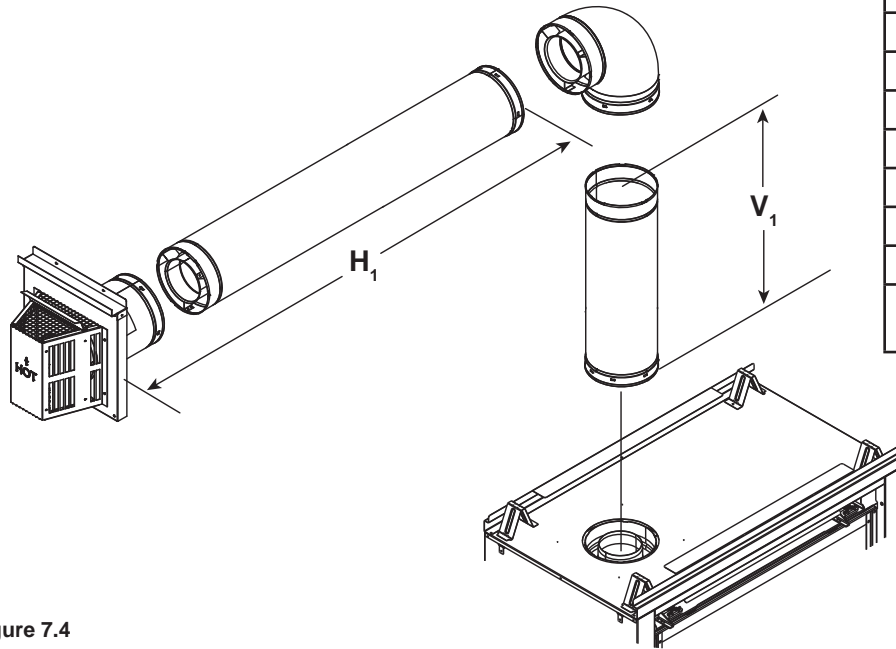

Figure 7.3 Minimum Installation Requirements for Two 45° Elbows-Top Vent-Horizontal Termination

# 1. Top Vent - Horizontal Termination - (continued)

## One Elbow



$V_1$ Minimum		$H_1$ Maximum	
Elbow only		1-1/2 ft.	457 mm
6 in.	152 mm	2-1/2 ft.	610 mm
1 ft.	305 mm	3 ft.	914 mm
2 ft.	610 mm	6 ft.	1.8 m
3 ft.	914 mm	9 ft.	2.7 m
4 ft.	1.2 m	12 ft.	3.7 m
5 ft.	1.5 m	15 ft.	4.6 m
6 ft.	1.8 m	18 ft.	5.5 m
$V_1 + H_1 = 50$ ft. (15.2 m) Maximum			
$H_1 = 18$ ft. (5.5 m) Maximum			

Figure 7.4

## Two Elbows

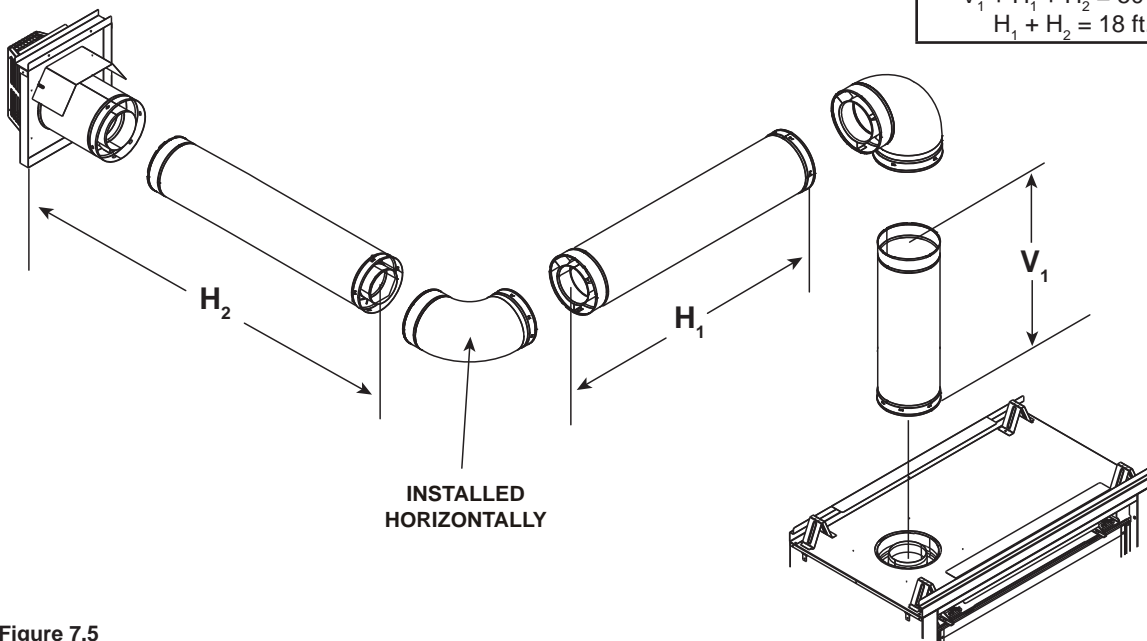

$V_1$ Minimum		$H_1 + H_2$ Maximum	
Elbow only		6 in.	152 mm
1 ft.	305 mm	2 ft.	610 mm
2 ft.	610 mm	4 ft.	1.2 m
3 ft.	914 mm	9 ft.	2.7 m
4 ft.	1.2 m	12 ft.	3.7 m
5 ft.	1.5 m	15 ft.	4.6 m
6 ft.	1.8 m	18 ft.	5.5 m
$V_1 + H_1 + H_2 = 50$ ft. (15.2 m) Maximum			
$H_1 + H_2 = 18$ ft. (5.5 m) Maximum			

Figure 7.5

# 1. Top Vent - Horizontal Termination - (continued)

## Three Elbows

V <sub>1</sub> Minimum		H <sub>1</sub> Maximum		V <sub>2</sub> Minimum		H <sub>2</sub> Maximum		V <sub>1</sub> + V <sub>2</sub> Minimum		H <sub>1</sub> + H <sub>2</sub> Maximum	
Elbow only		1 ft.	305 mm	6 in.	152 mm	1 ft.	305 mm	6 in.	152 mm	1 ft.	305 mm
6 in.	152 mm	3 ft.	914 mm	6 in.	152 mm	2 ft.	610 mm	1 ft.	305 mm	3 ft.	914 mm
1 ft.	305 mm	6 ft.	1.8 m	1 ft.	305 mm	6 ft.	1.8 m	2 ft.	610 mm	12 ft.	3.7 m
2 ft.	610 mm	10 ft.*	3 m	2 ft.	610 mm	10 ft.*	3 m	4 ft.	1.2 m	18 ft.	5.5 m
3 ft.	914 mm	12 ft.*	3.7 m	3 ft.	914 mm	12 ft.*	3.7 m	6 ft.	1.8 m	18 ft.	5.5 m
*H <sub>1</sub> + H <sub>2</sub> = 18 ft. (5.5 m) Maximum						V <sub>1</sub> + V <sub>2</sub> + H <sub>1</sub> + H <sub>2</sub> = 50 ft. (15.2 m) Maximum					

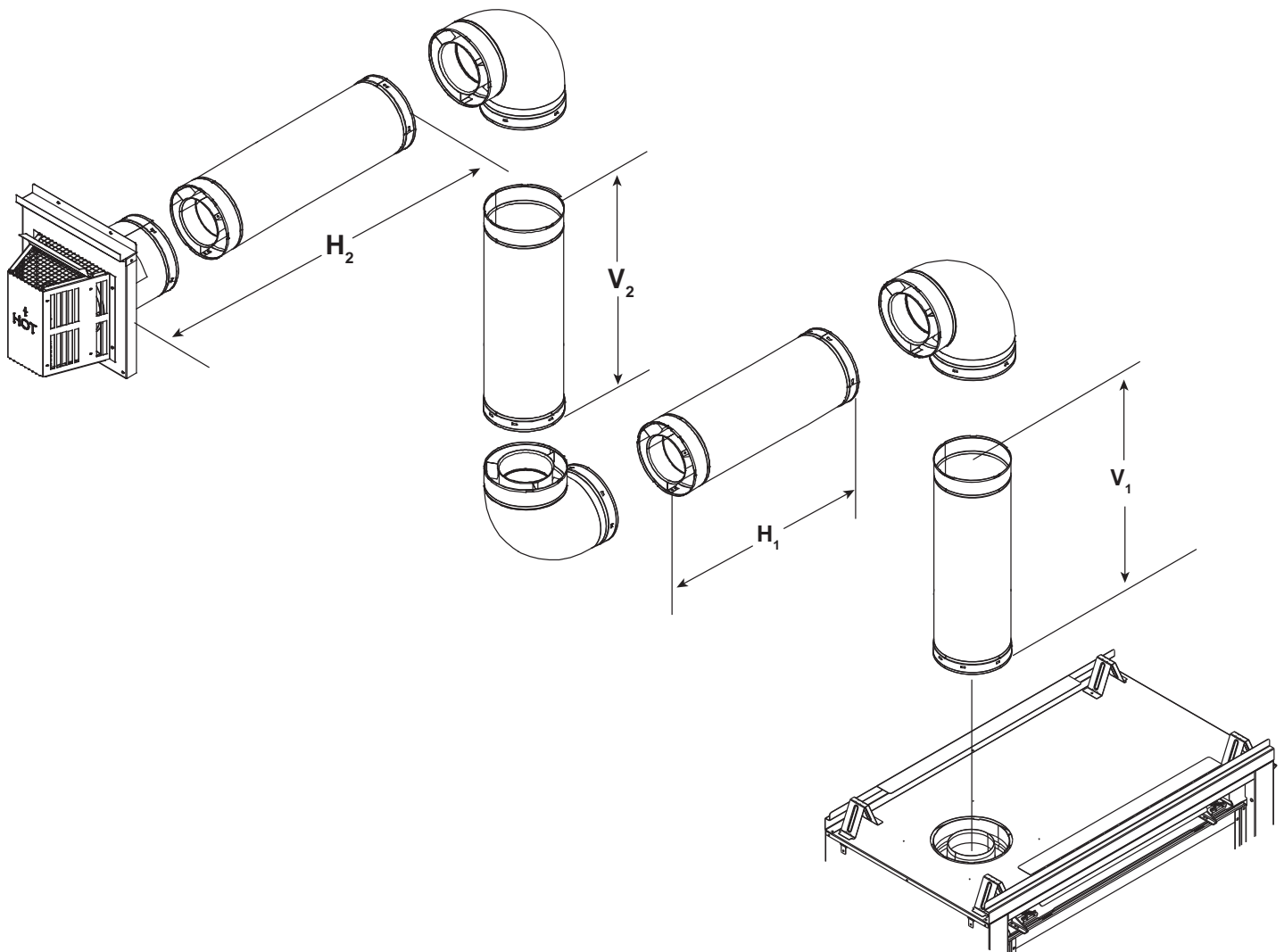
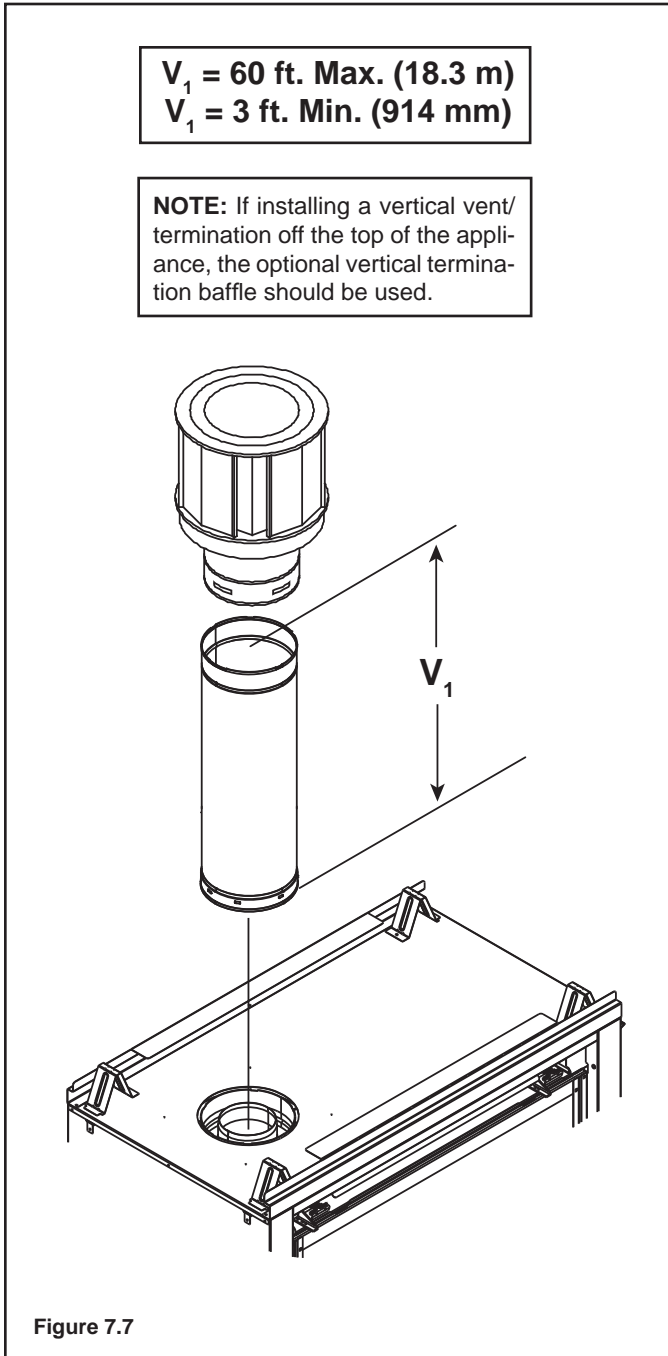

Figure 7.6



## 2. Top Vent - Vertical Termination No Elbow



Exhaust restrictors are recommended for these vertically terminated products which have excessive draft. Exhaust restrictors will compensate for high draft, and restore visual flame height. If the vent configuration has a total vertical of 15-60 feet, an exhaust restrictor may be needed. The exhaust restrictor can be located in the appliance manual bag.

## Exhaust restrictor Instructions

1. Remove refractory panel and exhaust baffle from pilot side of appliance. Use a 1/4 inch nut driver and remove the two screws that secure it in place. To remove the exhaust baffle, remove the three screws securing the refractory panel in place. See Figure 7.8.

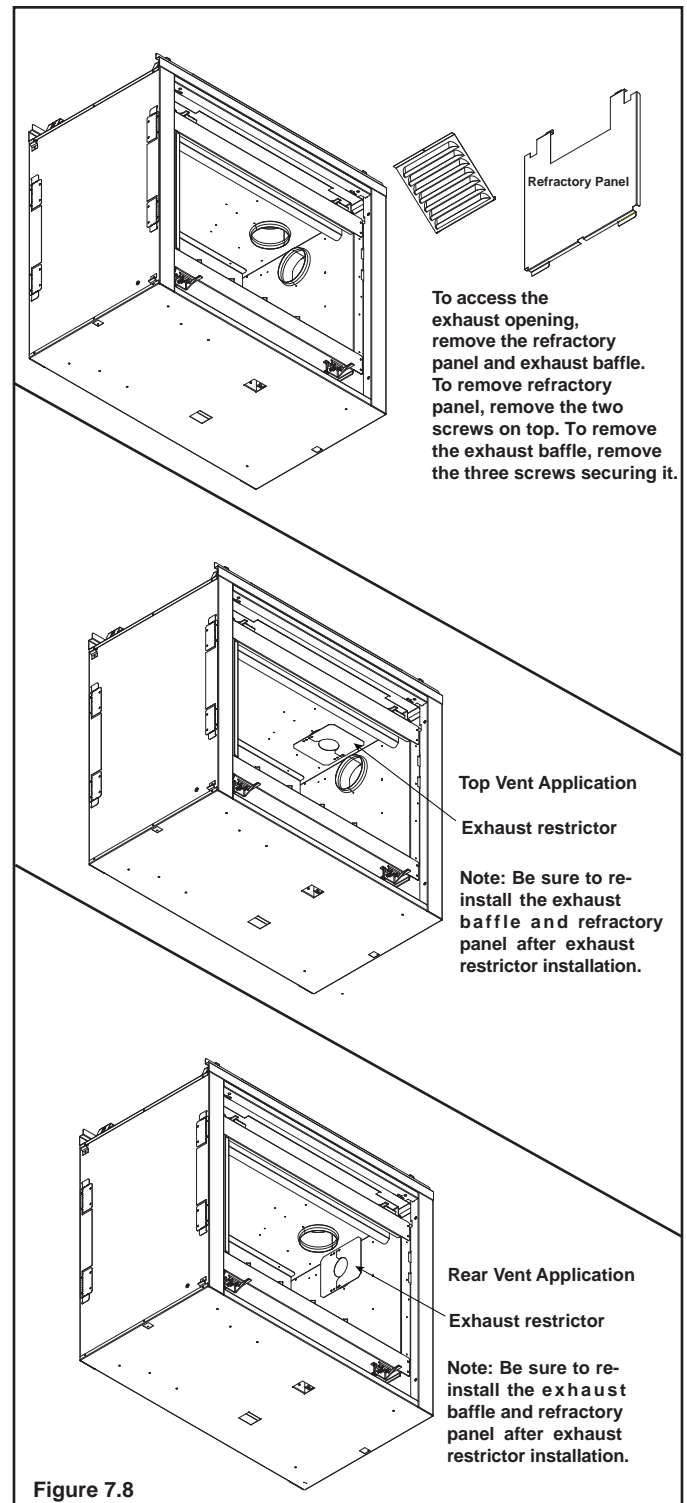

2. Break the exhaust restrictor into two pieces. Do this by bending the part back and forth until it breaks (see Figure 7.9).

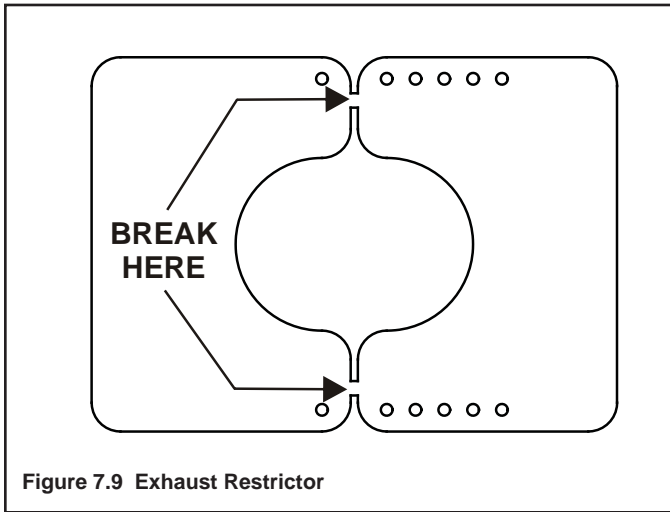

Figure 7.9 Exhaust Restrictor

3. Match the amount of vertical you have in the system with the chart to find the appropriate position to set the exhaust restrictor (see Figure 7.10).

Vertical	TOP VENT		REAR VENT	
	NG	LP	NG	LP
4 ft.	1-1	No Restrictor	No Restrictor	No Restrictor
8 ft.	2-2	1-2	1-1	No Restrictor
15 ft.	3-3	3-2	2-2	1-2
20 ft.	3-4	3-3	3-3	2-3
25 ft.	3-4	3-3	3-3	2-3
30 ft.	4-4	3-4	3-4	3-3
35 ft.	4-4	3-4	3-4	3-3
40 ft.	5-4	4-4	4-4	3-4
45 ft.	5-4	4-4	4-4	3-4
50 ft.	5-5	5-4	5-4	4-4
55 ft.	5-5	5-4	5-4	4-4

**Note:** If the DVP-2SL adapter and SLP pipe is used, you MUST subtract one number from the table above.

**Example:** Top vent 40 ft vertical with DVP pipe = 5-4  
 Top vent 40 ft vertical with SLP pipe = 4-3

4. Center the exhaust restrictor in the open end of the exhaust outlet and secure through the slots on the exhaust restrictor with the 2-1/4 in. self tapping screws provided in the appliance manual bag.
5. Reinstall the refractory panel.

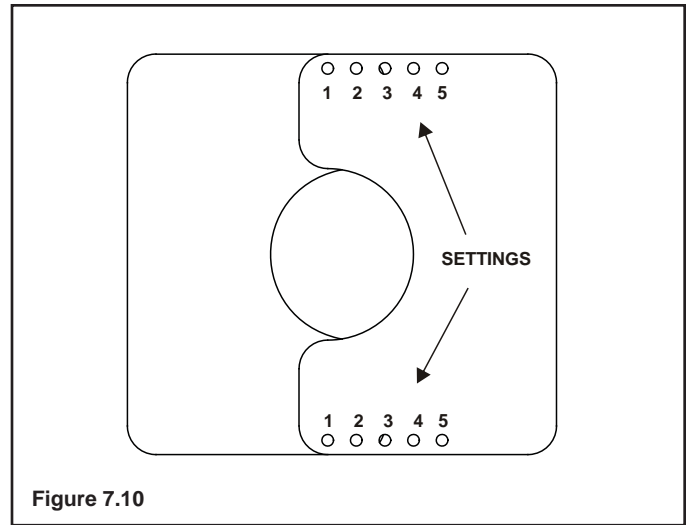
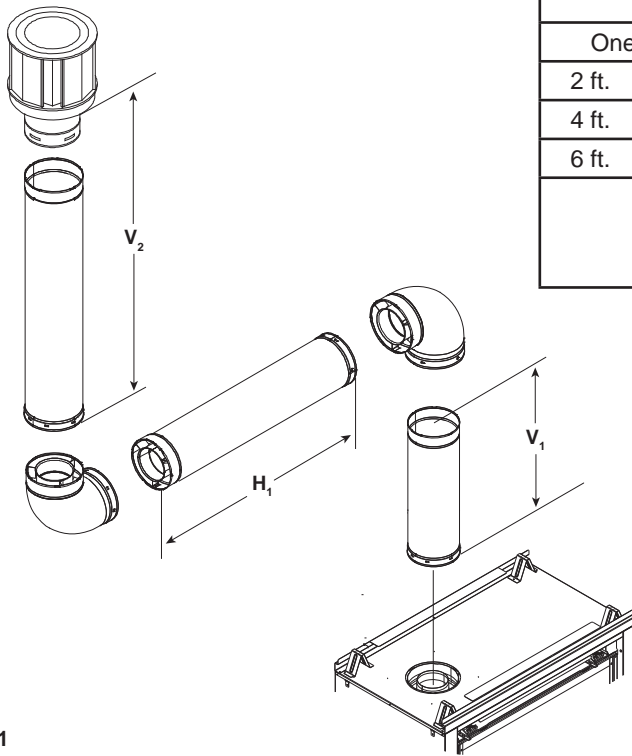

Figure 7.10

## Two Elbows



$V_1$		$H_1$ Maximum		$V_2$	$V_1 + V_2$ Minimum	
One Elbow		2-1/2 ft.	762 mm	*	*	*
2 ft.	607 mm	6 ft.	1.8 m	*	*	*
4 ft.	1.2 m	12 ft.	3.7 m	*	*	*
6 ft.	1.8 m	18 ft.	5.5 m			
$V_1 + V_2 + H_1 = 50$ ft (15.2 m) Maximum *No specific restrictions on this value EXCEPT $V_1 + V_2 + H_1$ cannot exceed 50 ft (15.2 m)						

Figure 7.11

## Three Elbows

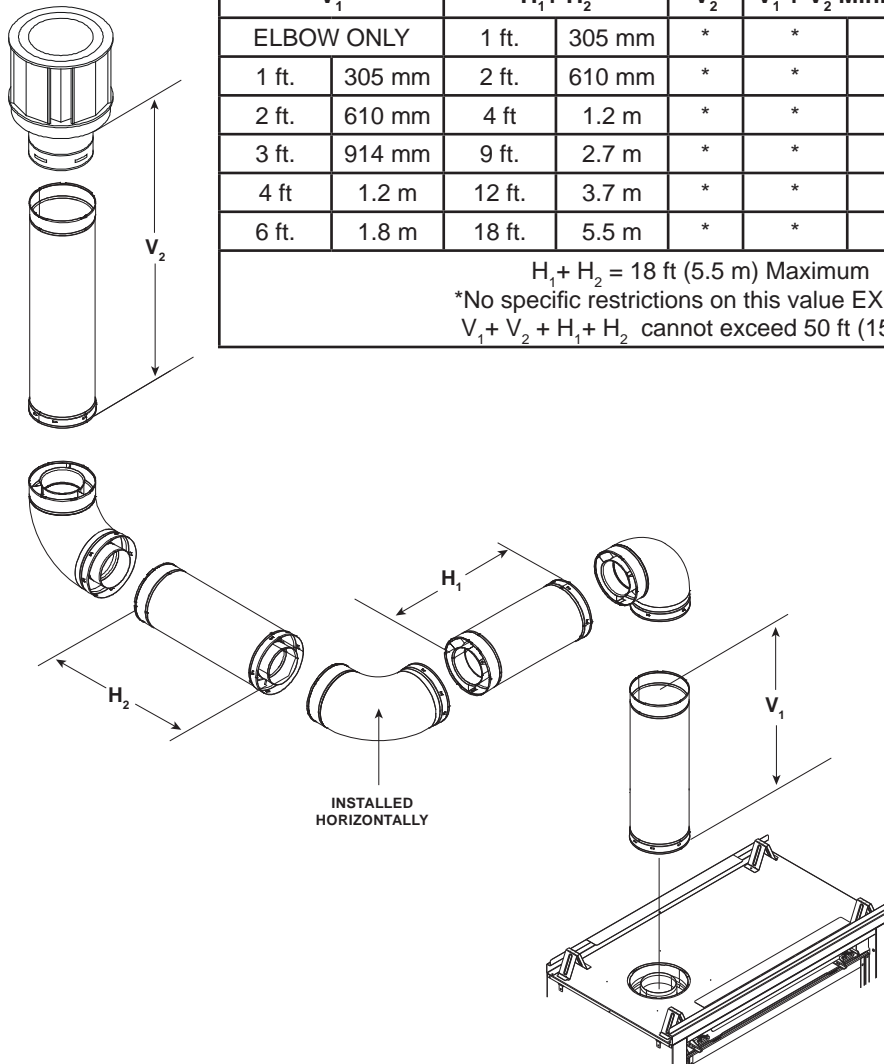

$V_1$		$H_1 + H_2$		$V_2$	$V_1 + V_2$ Minimum		$H_1 + H_2$ Maximum	
ELBOW ONLY		1 ft.	305 mm	*	*	*	1 ft.	305 mm
1 ft.	305 mm	2 ft.	610 mm	*	*	*	2 ft.	610 mm
2 ft.	610 mm	4 ft.	1.2 m	*	*	*	4 ft.	1.2 m
3 ft.	914 mm	9 ft.	2.7 m	*	*	*	9 ft.	2.7 m
4 ft.	1.2 m	12 ft.	3.7 m	*	*	*	12 ft.	3.7 m
6 ft.	1.8 m	18 ft.	5.5 m	*	*	*	18 ft.	5.5 m
$H_1 + H_2 = 18$ ft (5.5 m) Maximum *No specific restrictions on this value EXCEPT $V_1 + V_2 + H_1 + H_2$ cannot exceed 50 ft (15.2 m)								

Figure 7.12

### 3. Rear Vent - Horizontal Termination

No Elbow

$H_1 = 16 \text{ in. (406 mm) Maximum}$

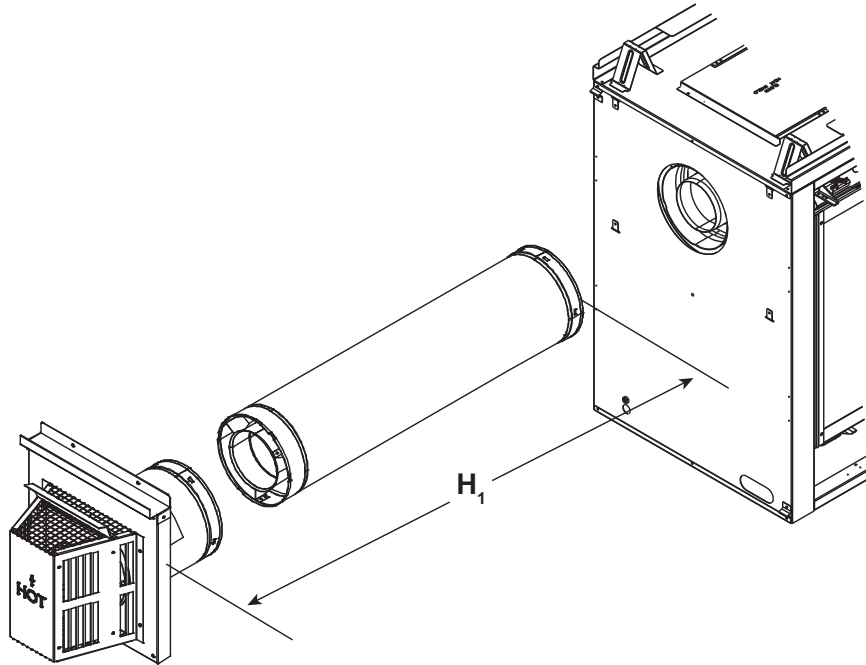

Figure 7.13

One 45° Elbow

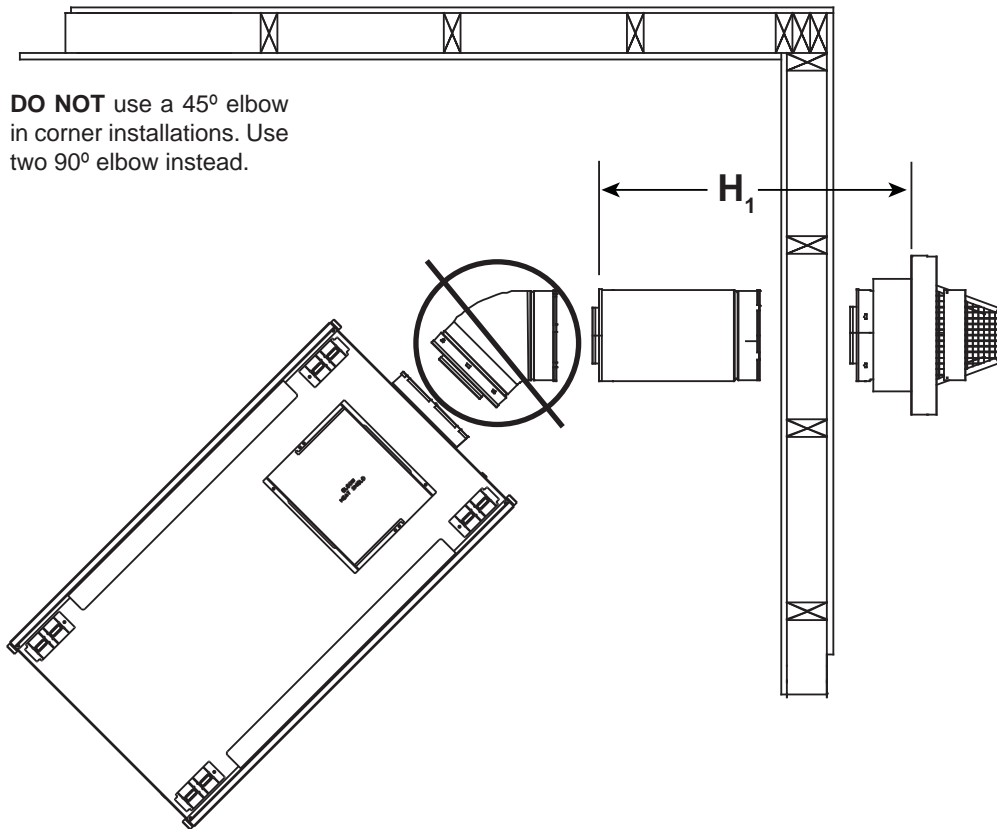

Figure 7.14

### 3. Rear Vent - Horizontal Termination - (continued)

#### Two Elbows

H <sub>1</sub> Maximum		V <sub>1</sub> Minimum		H <sub>2</sub> Maximum		H <sub>1</sub> + H <sub>2</sub> Maximum	
1 ft.	610 mm	6 in.	152 mm	1 ft.	305 mm	1 ft.	305 mm
2 ft.	914 mm	1 ft.	305 mm	2 ft.	610 mm	3 ft.	914 mm
3 ft.	914 mm	2 ft.	610 mm	4 ft.	1.2 m	6 ft.	1.8 m
3 ft.	914 mm	3 ft.	914 mm	7 ft.	2.1 m	9 ft.	2.7 m
3 ft.	914 mm	4 ft.	1.2 m	10 ft.	3 m	12 ft.	3.7 m
3 ft.	914 mm	5 ft.	1.5 m	12 ft.	3.7 m	15 ft.	4.6 m
3 ft.	914 mm	6 ft.	1.8 m	15 ft.	4.6 m	18 ft.	5.5 m
V <sub>1</sub> + H <sub>1</sub> + H <sub>2</sub> = 50 ft (15.2 m) Maximum    H <sub>1</sub> = 3 ft (914 mm) Maximum *H <sub>1</sub> + H <sub>2</sub> = 18 ft (5.5 m) Maximum							

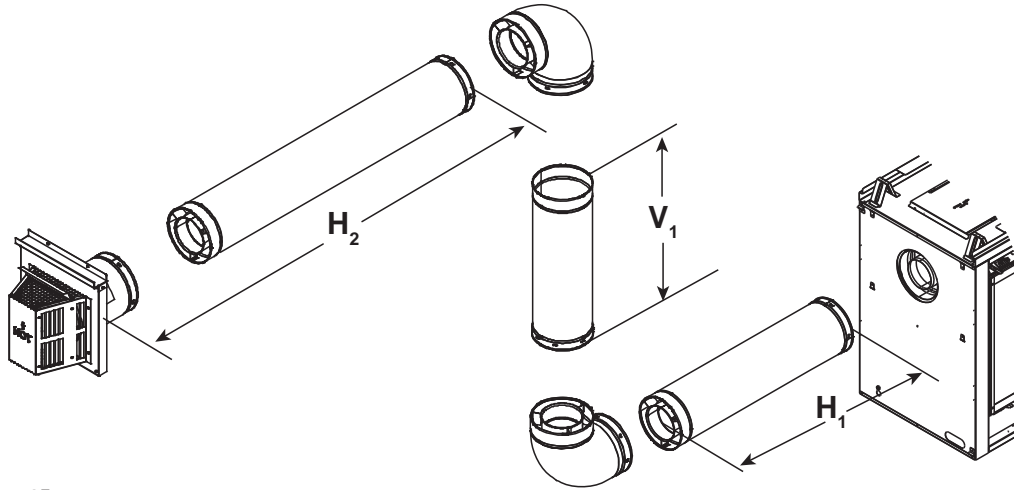

Figure 7.15

#### Three Elbows

H <sub>1</sub> Maximum		V <sub>1</sub> Minimum		H <sub>2</sub> + H <sub>3</sub>		H <sub>1</sub> + H <sub>2</sub> + H <sub>3</sub> Maximum	
6 in.	152 mm	6 in.	152 mm	6 in.	152 mm	1 ft.	305 mm
1 ft.	305 mm	1 ft.	305 mm	2 ft.	610 mm	3 ft.	914 mm
3 ft.	914 mm	2 ft.	610 mm	3 ft.	914 mm	6 ft.	1.8 m
3 ft.	914 mm	3 ft.	914 mm	6 ft.	1.8 m	9 ft.	2.7 m
3 ft.	914 mm	4 ft.	1.2 m	9 ft.	2.7 m	12 ft.	3.7 m
V <sub>1</sub> + H <sub>1</sub> + H <sub>2</sub> + H <sub>3</sub> = 40 ft (12.2 m) Maximum    H <sub>1</sub> = 3 ft (94 mm) Maximum H <sub>1</sub> + H <sub>2</sub> + H <sub>3</sub> = 12 ft (3.7 m) Maximum							

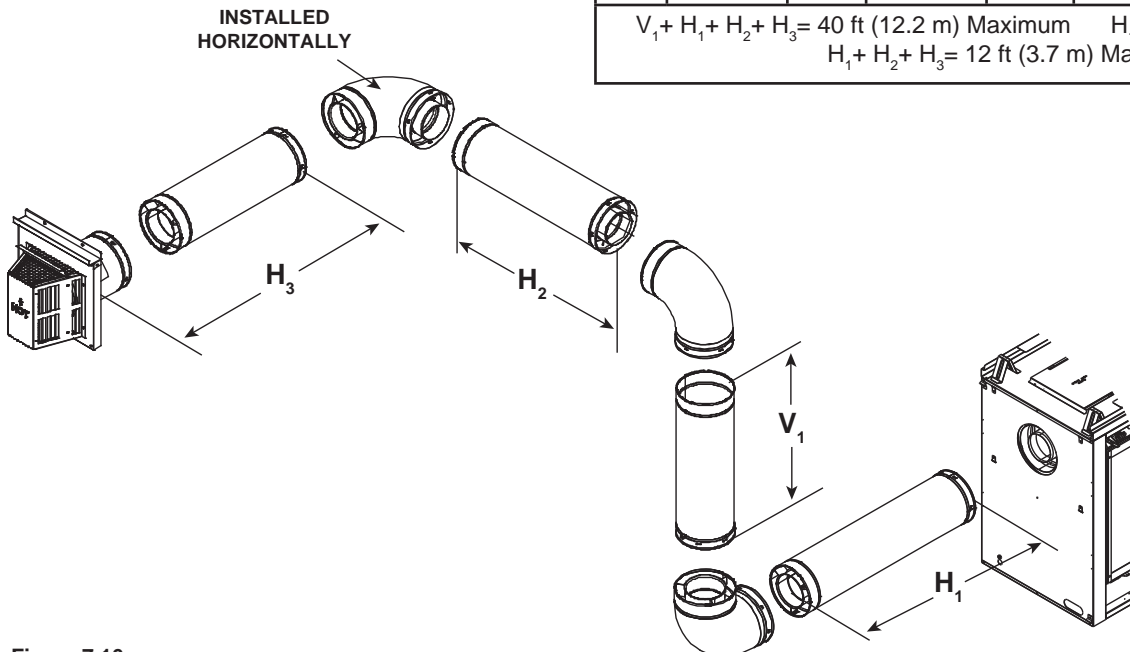
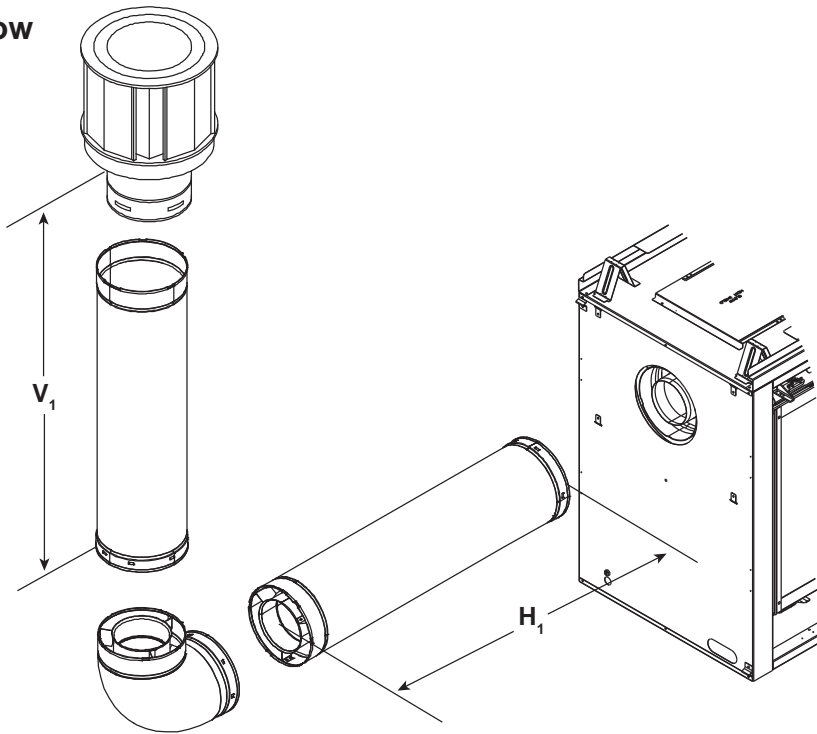

Figure 7.16

## 4. Rear Vent - Vertical Termination

### One Elbow



V <sub>1</sub> Minimum		H <sub>1</sub> Maximum	
1 ft.	305 mm	3 ft.	914 mm
2 ft.	610 mm	5 ft.	1.5 m
3 ft.	914 mm	7 ft.	2.1 m
4 ft.	1.2 m	8 ft.	2.4 m
5 ft.	1.5 m	8 ft.	2.4 m
V <sub>1</sub> + H <sub>1</sub> = 40 ft (12.2 m) Maximum			

Figure 7.17

### Two Elbows

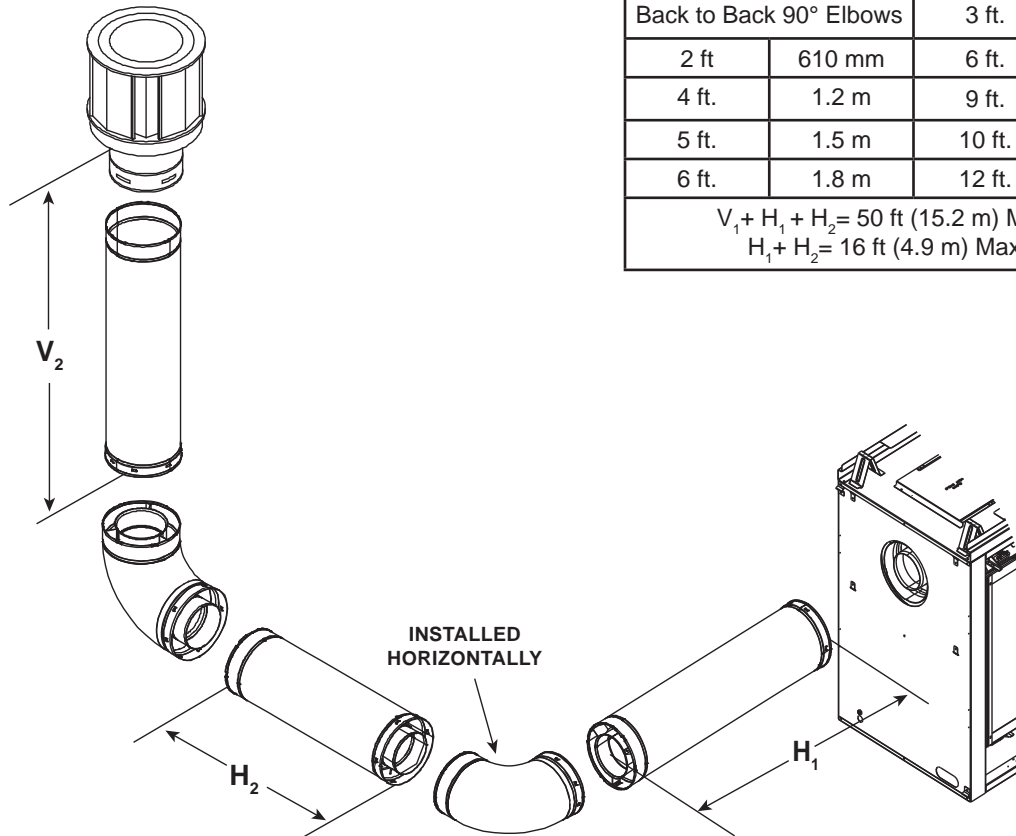

V <sub>1</sub> Minimum		H <sub>1</sub> + H <sub>2</sub> Maximum	
Back to Back 90° Elbows		3 ft.	914 mm
2 ft.	610 mm	6 ft.	1.8 m
4 ft.	1.2 m	9 ft.	2.7 m
5 ft.	1.5 m	10 ft.	3 m
6 ft.	1.8 m	12 ft.	3.7 m
V <sub>1</sub> + H <sub>1</sub> + H <sub>2</sub> = 50 ft (15.2 m) Maximum			
H <sub>1</sub> + H <sub>2</sub> = 16 ft (4.9 m) Maximum			

Figure 7.18



#### 4. Rear Vent - Vertical Termination - (continued)

##### Three Elbows

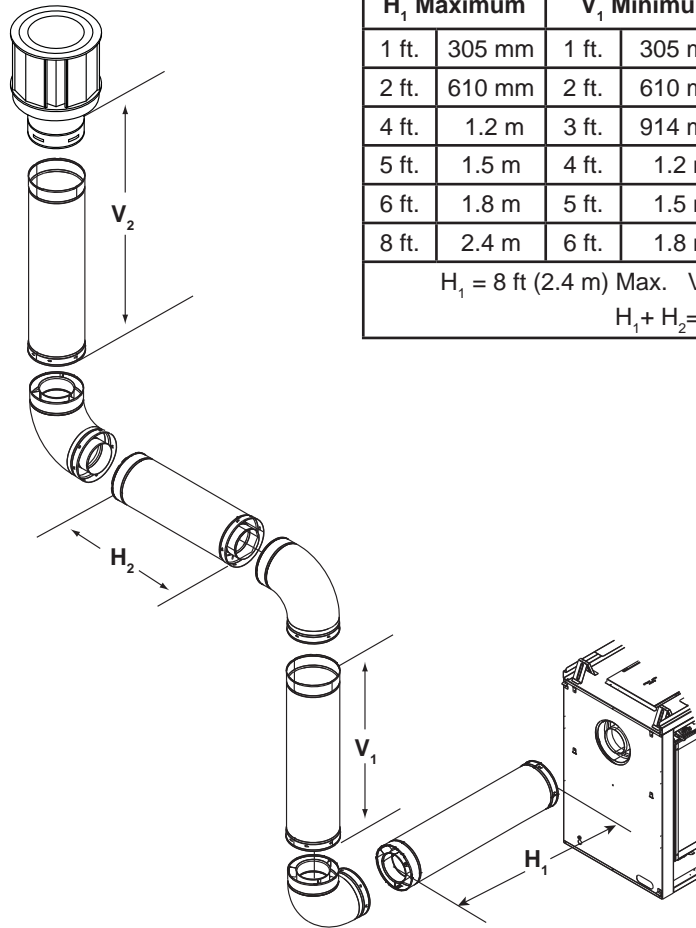

H <sub>1</sub> Maximum		V <sub>1</sub> Minimum		H <sub>2</sub>		H <sub>1</sub> + H <sub>2</sub> Maximum	
1 ft.	305 mm	1 ft.	305 mm	1 ft.	305 mm	2 ft.	610 mm
2 ft.	610 mm	2 ft.	610 mm	3 ft.	914 mm	5 ft.	1.5 m
4 ft.	1.2 m	3 ft.	914 mm	4 ft.	1.2 m	8 ft.	4.6 m
5 ft.	1.5 m	4 ft.	1.2 m	6 ft.	1.8 m	11 ft.	3.4 m
6 ft.	1.8 m	5 ft.	1.5 m	8 ft.	2.4 m	14 ft.	4.3 m
8 ft.	2.4 m	6 ft.	1.8 m	9 ft.	2.7 m	17 ft.	5.2 m

$H_1 = 8 \text{ ft. (2.4 m) Max.}$      $V_1 + V_2 + H_1 + H_2 = 50 \text{ ft. (15.2 m) Max.}$   
 $H_1 + H_2 = 17 \text{ ft. (5.2 m) Max.}$

Figure 7.19

##### Three Elbows

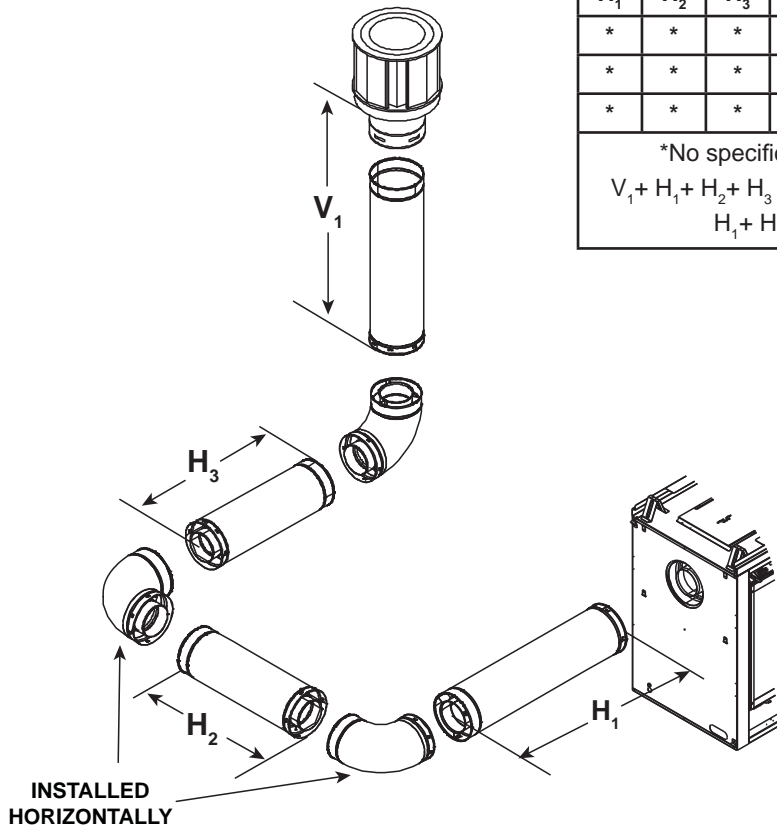

H <sub>1</sub>	H <sub>2</sub>	H <sub>3</sub>	V <sub>1</sub> Minimum		H <sub>1</sub> + H <sub>2</sub> + H <sub>3</sub> Maximum	
*	*	*	8 ft.	2.4 m	4 ft.	1.2 m
*	*	*	9 ft.	2.7 m	5 ft.	1.5 m
*	*	*	10 ft.	3.1 m	6 ft.	1.8 m

\*No specific restrictions on this value EXCEPT  
 $V_1 + H_1 + H_2 + H_3$  cannot exceed 50 ft. (15.2 m) Maximum  
 $H_1 + H_2 + H_3 = 6 \text{ ft. (1.8 m) Maximum}$

Figure 7.20

# 8 Vent Clearances and Framing

## A. Pipe Clearances to Combustibles

**WARNING! Risk of Fire! Maintain air space clearance to vent. DO NOT pack insulation or other combustibles:**

- Between ceiling firestops
- Between wall shield firestops
- Around vent system

Failure to keep insulation or other material away from vent pipe may cause over heating and fire.

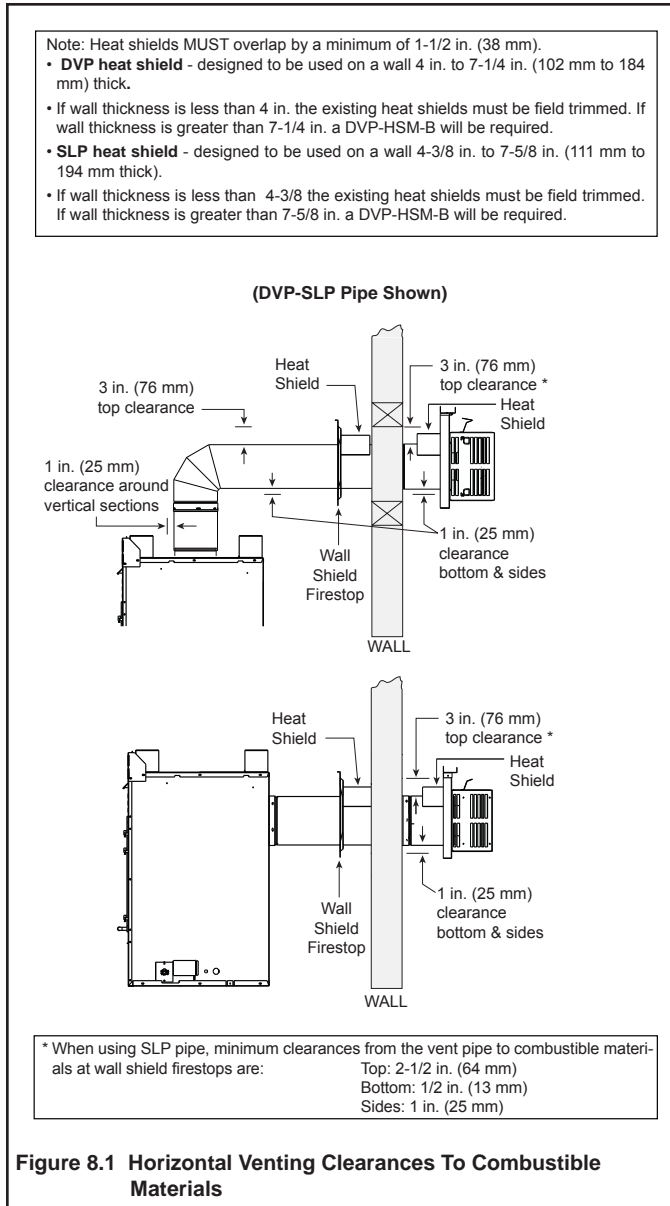

## B. Wall Penetration Framing

### Combustible Wall Penetration

Whenever a combustible wall is penetrated, you must frame a hole for the wall shield firestop(s). The wall shield firestop maintains minimum clearances and prevents cold air infiltration.

- The opening must be framed on all four sides using the same size framing materials as those used in the wall construction.
- SLP pipe - A wall shield firestop must be placed on each side of an interior wall. A minimum 1-1/2 in. (38 mm) overlap of attached heat shields must be maintained.
- DVP pipe - A wall shield firestop is required on one side only on interior walls. If your local inspector requires a wall shield firestop on both sides, then both wall shield firestops must have a heat shield (refer to Section 16.B.) attached to them.
- See Section 10.M. for information for regarding the installation of a horizontal termination cap.

### Non-Combustible Wall Penetration

If the hole being penetrated is surrounded by noncombustible materials such as concrete, a hole with diameter one in. greater than the pipe is acceptable.

Whenever a non-combustible wall is penetrated, the wall shield firestop is only required on one side and no heat shield is necessary.

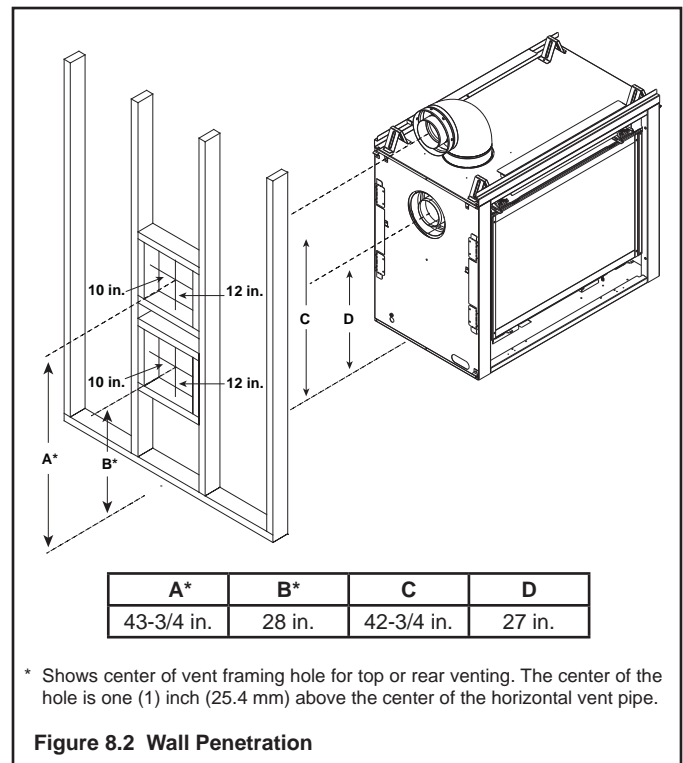

**Note:** When venting off the top of the unit and terminating horizontally, using SLP pipe, a 10 in. x 10 in. framing hole is required.

## C. Vertical Penetration Framing

A ceiling firestop **MUST** be used between floors and attics.

- **DVP pipe only** - Frame an opening 10 in. by 10 in. (254 mm by 254 mm) whenever the vent penetrates a ceiling/floor (see Figure 8.3).
- **SLP pipe only** - Frame opening 9 in. x 9 in. (229 mm x 229 mm) whenever the vent penetrates a ceiling/floor (see Figure 8.3).
- Frame the area with the same sized lumber as used in ceiling/floor joist.
- The ceiling firestop may be installed above or below the ceiling joists when installed with a attic insulation shield. It must be under joists between floors that are not insulated. Refer to Figure 8.4.
- Secure with three fasteners on each side.

**WARNING! Risk of Fire! DO NOT pack insulation around the vent. Insulation must be kept back from the pipe to prevent overheating.**

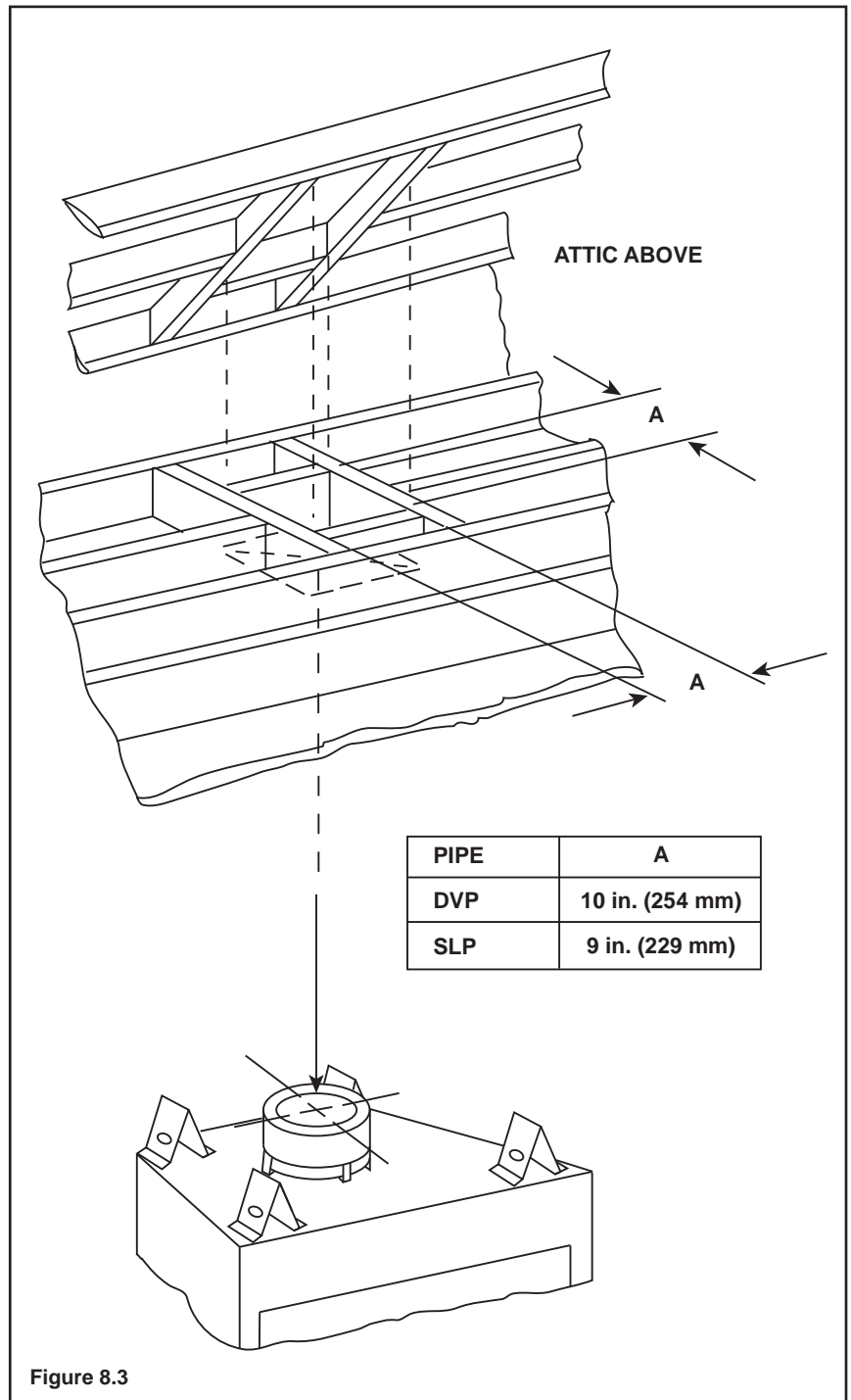

Figure 8.3

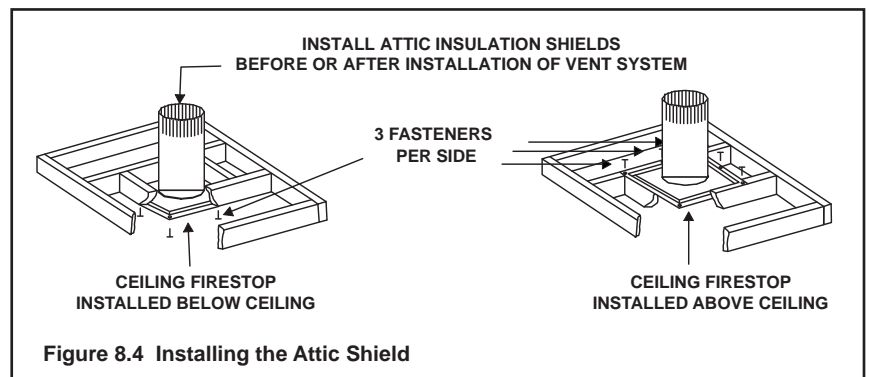

Figure 8.4 Installing the Attic Shield

## D. Install Attic Insulation Shield

**WARNING! Fire Risk. DO NOT** allow loose materials or insulation to touch vent. *Hearth & Home Technologies Inc. requires the use of an attic shield.*

The National Fuel Gas Code ANSI Z223.1 and NFPA 54 requires an attic shield constructed of 26 gauge minimum metal that extends at least 2 in. (51 mm) above insulation.

Attic shields must meet specified clearance and be secured in place.

### Flat Ceiling Installation

- Remove one shield from box.

**NOTICE:** *Cut previously installed batt insulation to make room for the attic insulation shield.*

- Wrap shield around pipe if pipe is already installed in area to be insulated.
- Match the three holes in each side and fasten with three screws to form a tube.
- Bend three tabs on the bottom of the shield outward to allow attachment to the ceiling firestop.
- Bend the remaining bottom tabs inward 90° to maintain the air space between the pipe and the shield. Set the shield on the ceiling firestop and attach to the firestop.
- Bend all tabs inward 90° around the top of the shield. These tabs must be used to prevent blown insulation from getting between the shield and vent pipe, and to maintain air space clearance.

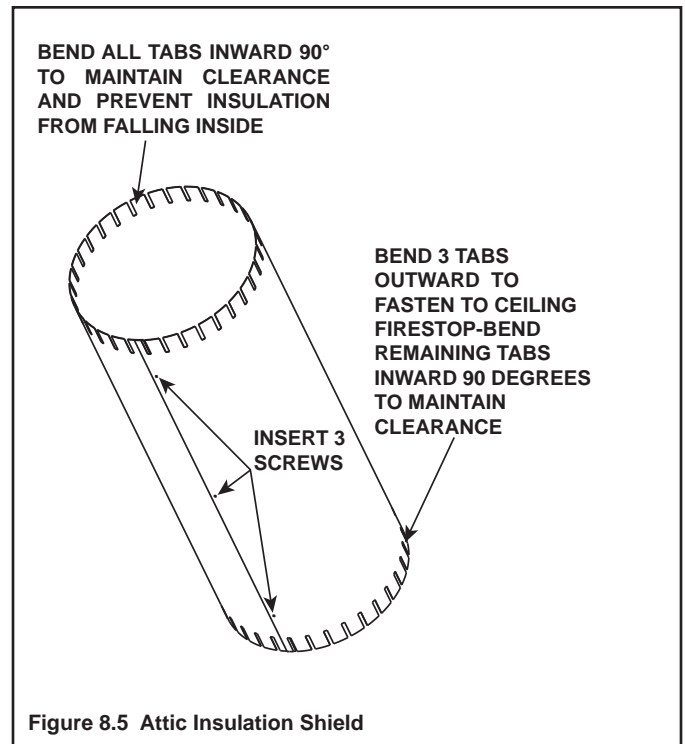

### Vaulted Ceiling Installation

- Remove one shield from box.

**NOTICE:** *Cut previously installed batt insulation to make room for the attic insulation shield.*

- Cut the attic insulation shield (if application is for vaulted ceiling) to fit your ceiling pitch. Snip cut edge to recreate 1 in. bend tabs all the way around the bottom.
- Wrap shield around pipe if pipe is already installed in area to be insulated.
- Match the three holes in each side and fasten with three screws to form a tube.
- Bend three tabs on the bottom of the shield outward to allow attachment to the ceiling firestop.
- Bend the remaining bottom tabs inward 90° to maintain the air space between the pipe and the shield. Set the shield on the ceiling firestop and attach to the firestop.
- Bend all tabs inward 90° around the top of the shield. These tabs must be used to prevent blown insulation from getting between the shield and vent pipe, and to maintain air space clearance.

# 9 Appliance Preparation

## A. Top Vent

**CAUTION! Risk of Cuts, Abrasions or Flying Debris.** Wear protective gloves and safety glasses during installation. Sheet metal edges are sharp.

**NOTICE:** Once appliance is set up for top or rear venting, it CANNOT be changed at a later time.

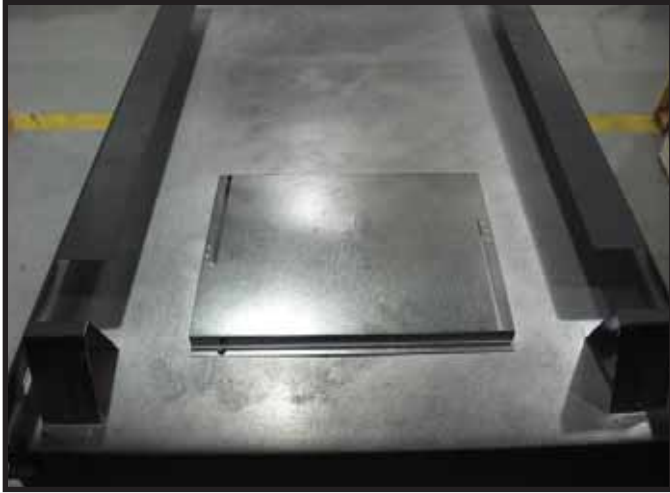

**Figure 9.1** Remove the elbow heat shield by removing the four screws holding it to the top of the appliance. Refer to Section 6B to determine if the elbow heat shield is required.

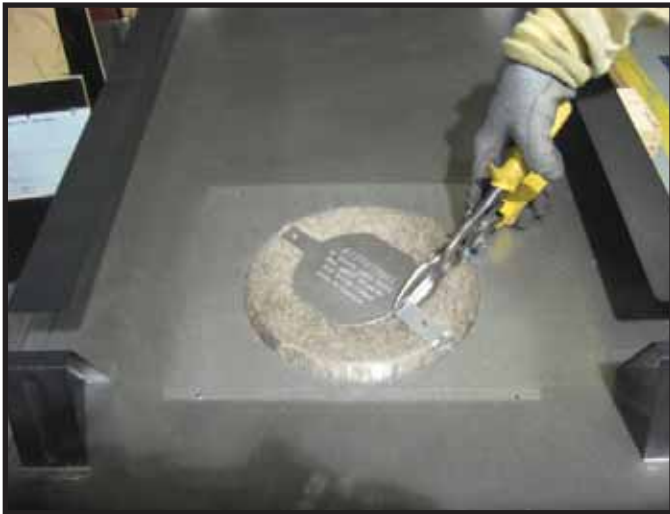

**Figure 9.2** Cut the metal retaining band and fold the sides out.

**NOTICE:** Once the vent cap has been removed it CANNOT be reattached.



**Figure 9.3** Fold the center parts of the retaining band up and use to remove the vent cap.



**Figure 9.4** Remove and discard the seal cap, insulation donut, insulation plug, and the insulation basket. Attach the first vent section (it will snap into place). Slide the vent gasket onto the vent section and then, up against the appliance. Secure the vent gasket to the appliance with two self-tapping screws found in the manual bag. Note: The vent gasket can found in the manual bag.

**Proceed to Section 9. C.**

## B. Rear Vent

**NOTICE:** Once appliance is set up for top or rear venting, it CANNOT be changed at a later time.



**Figure 9.5** Cut the metal retaining band.

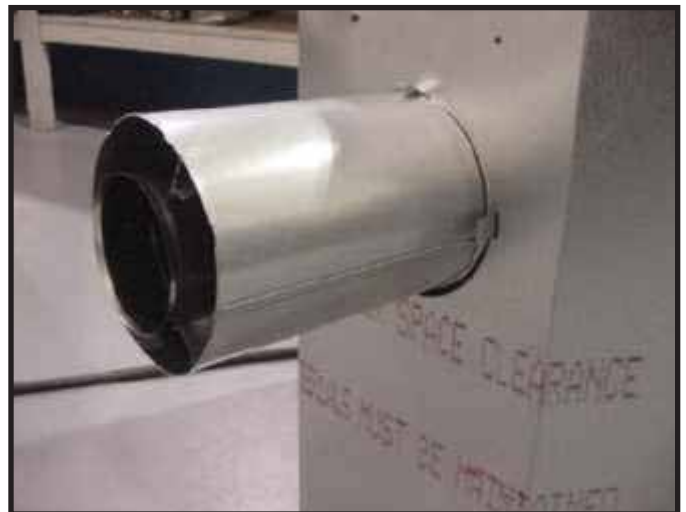

**Figure 9.6** Remove the seal cap.

**NOTICE:** Once the vent cap has been removed it CANNOT be reattached.



**Figure 9.7** Discard the seal cap, insulation plug and the insulation basket.



**Figure 9.8** Attach the first vent section (it will snap into place). Slide the vent gasket onto the vent section and then, up against the appliance. Secure the vent gasket to the appliance with two self-tapping screws found in the manual bag. Note: The vent gasket can found in the manual bag.



## C. Securing and Leveling the Appliance

**WARNING! Risk of Fire!** Prevent contact with:

- Sagging or loose insulation
- Insulation backing or plastic
- Framing and other combustible materials

Block openings into the chase to prevent entry of blown-in insulation. Make sure insulation and other materials are secured.

**DO NOT** notch the framing around the appliance standoffs.

Failure to maintain air space clearance may cause overheating and fire.

**NOTICE:** Failure to ensure that the fireplace opening is square may result in the decorative front not fitting properly.

The diagram shows how to properly position, level, and secure the appliance (see Figure 9.8). Nailing tabs are provided to secure the appliance to the framing members.

1. Venting - refer to Vent Clearances and Framing (Section 8) for hole location.
2. Place the appliance into position, making sure to maintain proper clearance to combustibles.
3. Level the appliance from side to side and front to back. It is acceptable to use wood shims under the appliance.
4. Fasten the appliance to the floor using the pilot holes located at the bottom of the appliance.
5. Bend out nailing tabs on each side making sure to keep the nailing tabs flush with the framing.
6. Using a framing square, make sure that the sides of the appliance are square to the bottom as shown in Figure 9.9.
7. Secure the appliance to the framing by using nails or screws through the nailing tabs. It is acceptable to use plumber strap to secure the unit to the framing if necessary. Be sure to maintain all clearances to combustible material.

**Note:** Once appliance is setup for top or rear venting, it CANNOT be changed at a later time.

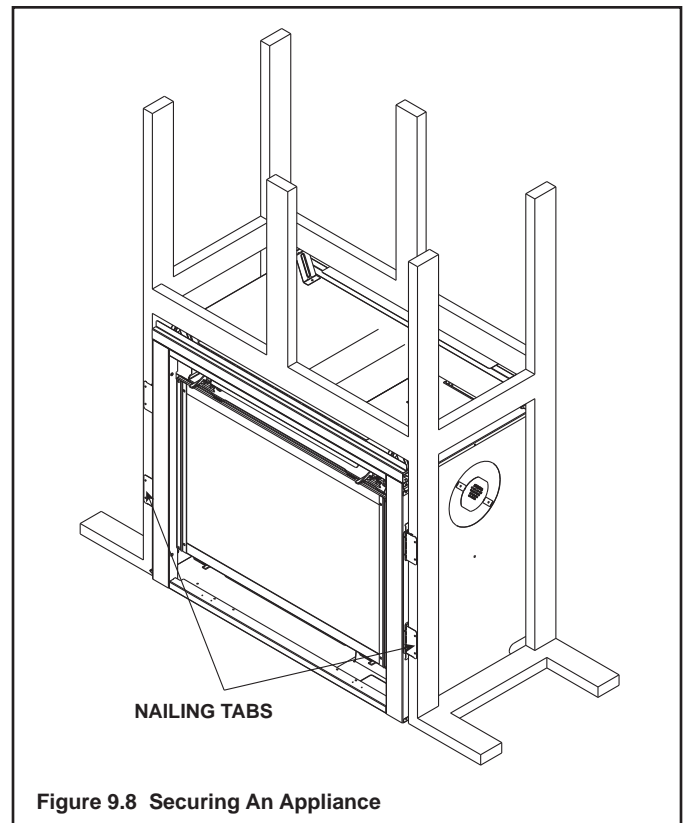

Figure 9.8 Securing An Appliance

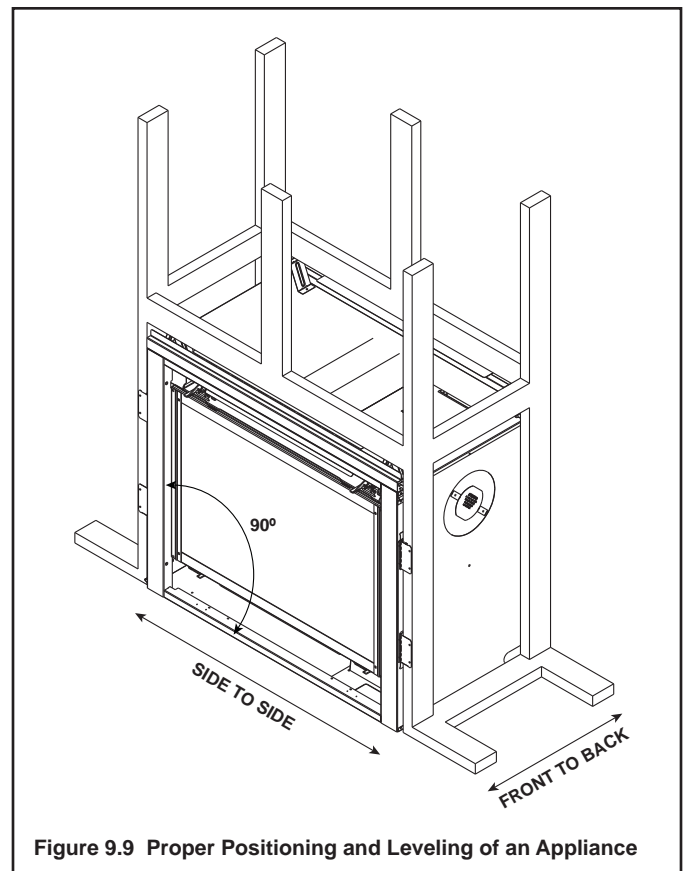

Figure 9.9 Proper Positioning and Leveling of an Appliance

# 10 Installing Vent Pipe (DVP and SLP Pipe)

## A. Assemble Vent Sections (DVP Pipe Only)

### Attach Vent to the Firebox Assembly

**Note:** The end of the pipe sections with the lanced tabs will face toward the appliance.

Attach the first pipe section to the starting collar:

- Lanced pipe end to the starting collar
- Inner pipe over inner collar
- Push the pipe section until all lanced tabs snap in place
- Lightly tug on pipe to confirm it has locked.

### Commercial, Multi-family (Multi-level exceeding two stories), or High-Rise Applications

All outer pipe joints must be sealed with high temperature silicone, including the slip section that connects directly to the horizontal termination cap.

- Apply a bead of silicone sealant inside the female outer pipe joint prior to joining sections. See Figure 10.1
- Only outer pipes need to be sealed. All unit collar, pipe, slip section, elbow and cap outer flues shall be sealed in this manner, unless otherwise stated.

**WARNING! Risk of Fire or Explosion! DO NOT break silicone seals on slip sections. Use care when removing termination cap from slip pipe. If slip section seals are broken during removal of the termination cap, vent may leak.**

### Assemble Pipe Sections (DVP Pipe Only)

Per Figure 10.2:

- Start the inner pipe on the lanced end of section A into the flared end of section B.
- Start the outer pipe of section A over the outer pipe of section B.
- Once both vents sections are started, push firmly until all lanced tabs lock into place.
- Lightly tug on the pipe to confirm the tabs have locked.

It is acceptable to use screws no longer than 1/2 in. (13 mm) to hold outer pipe sections together. If predrilling holes, **DO NOT** penetrate inner pipe.

For 90° and 45° elbows that are changing the vent direction from horizontal to vertical, one screw minimum should be put in the outer flue at the horizontal elbow joint to prevent the elbow from rotating. Use screws no longer than 1/2 in. (13 mm). If predrilling screw holes, **DO NOT** penetrate inner pipe.



Figure 10.1 High Temperature Silicone Sealant

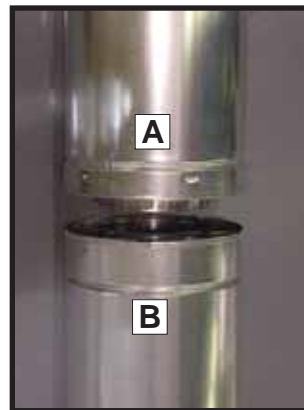

Figure 10.2

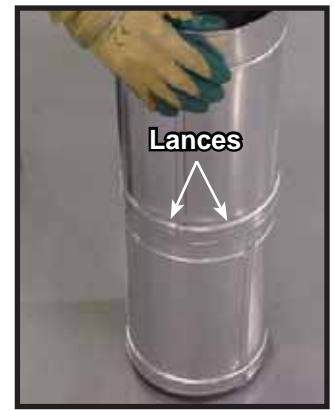

Figure 10.3

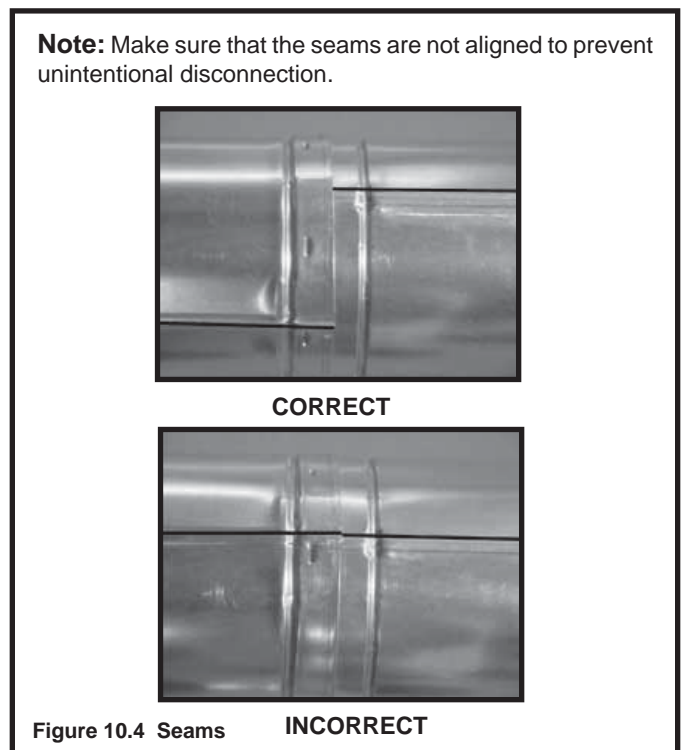

Figure 10.4 Seams

## B. Assemble Vent Sections (SLP Pipe Only)

To attach the first vent component to the starting collars of the appliance:

- Attach a DVP-2SL adapter to the starting collar of the appliance.
- Lock the vent components into place by sliding the pipe section onto the collar.
- Align the seam of the pipe and seam of collar to allow engagement. Rotate the vent component to lock into place. Use this procedure for all vent components. See Figure 10.5.
- Slide the gasket over the first vent section and place it flush to the appliance. This will prevent cold air infiltration. Caulk with a minimum of 300°F continuous exposure rating may be used to hold the part in place.
- Continue adding vent components, locking each succeeding component into place.
- Ensure that each succeeding vent component is securely fitted and locked into the preceding component.

### Commercial, Multi-family (Multi-level exceeding two stories), or High-Rise Applications

For installation into a commercial, multi-family (multi-level exceeding two stories) or high-rise applications: All outer pipe joints must be sealed with high temperature silicone, including the slip section that connects directly to the horizontal termination cap.

- Apply a bead of silicone sealant inside the female outer pipe joint prior to joining sections. See Figure 10.1.
- Only outer pipes need to be sealed. All unit collar, pipe, slip section, elbow and cap outer flues shall be sealed in this manner, unless otherwise stated.

**WARNING! Risk of Fire or Explosion! DO NOT break silicone seals on slip sections. Use care when removing termination cap from slip pipe. If slip section seals are broken during removal of the termination cap, vent may leak.**

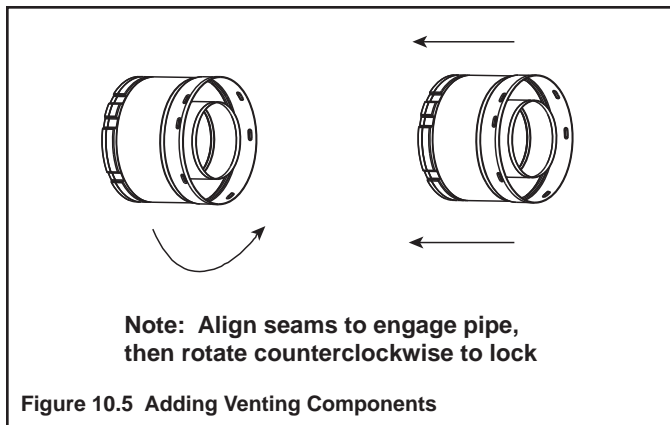

## C. Assemble Slip Sections

- Slide the inner flue of the slip section into the inner flue of the pipe section and the outer flue of the slip section over the outer flue of the pipe section. See Figure 10.6.
- Slide together to the desired length.

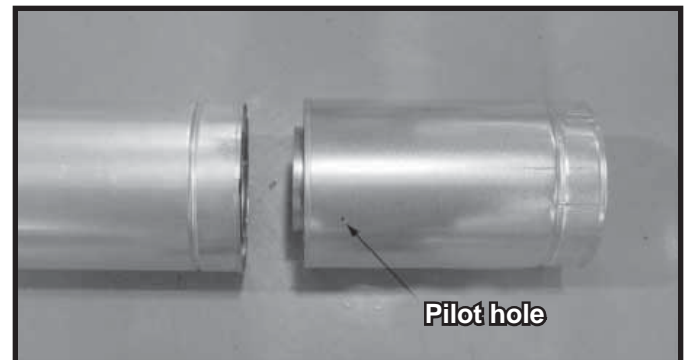

**Figure 10.6 Slip Section Pilot Holes**

- Maintain a 1-1/2 in. (38 mm) overlap between the slip section and the pipe section.
- Secure the pipe and slip section with two screws no longer than 1/2 in. (13 mm), using the pilot holes in the slip section. See Figure 10.7.

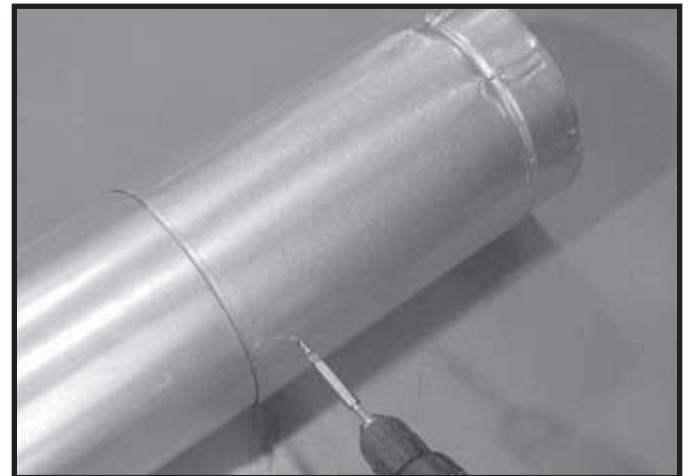

**Figure 10.7 Screws into Slip Section**

- Continue adding pipe as necessary following instructions in "Assembling Pipe Sections."

**NOTICE:** If slip section is too long, the inner and outer flues of the slip section can be cut to the desired length.

**NOTICE:** When installing a vent system with an HRC termination cap, all pipe system joints shall be sealed using a high temperature silicone sealant.

- Apply a bead of silicone sealant inside the female outer pipe joint prior to joining sections.
- Only outer pipes are sealed, sealing the inner flue is not required.
- All unit collar, pipe, slip section, elbow and cap outer flues shall be sealed.

## D. Secure the Vent Sections

- Vertical runs of DVP pipe must be supported every 8 ft. (2.44 m) after the 25 ft. (7.62 m) maximum unsupported rise.
- Vertical runs of SLP pipe must be supported every 8 ft. (2.44 m).
- Horizontal sections must be supported every 5 feet (1.52 m).
- Vent supports or plumbers strap (spaced 120° apart) may be used to support. See Figures 10.8 and 10.9.
- Wall shield firestops may be used to provide horizontal support.
- SLP ceiling firestops have tabs that may be used to provide vertical support.

**WARNING! Risk of Fire, Explosion or Asphyxiation!** Improper support may allow vent to sag and separate. Use vent run supports and connect vent sections per installation instructions. **DO NOT** allow vent to sag below connection point to appliance.

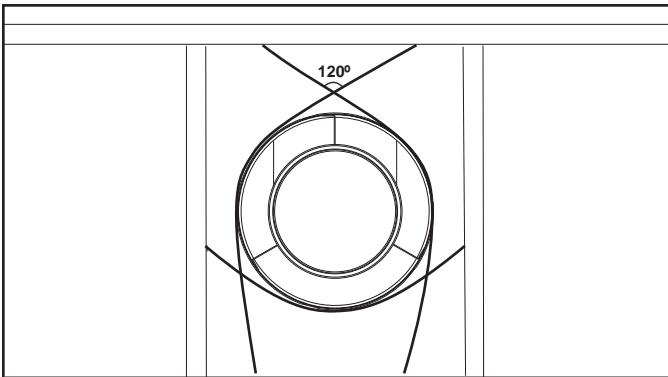

Figure 10.8 Securing Vertical Pipe Sections

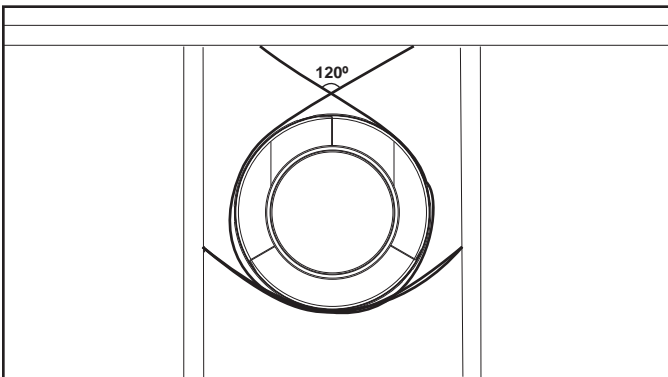

Figure 10.9 Securing Horizontal Pipe Sections

## E. Disassemble Vent Sections

- Rotate either section (see Figure 10.10) so the seams on both pipe sections are aligned as shown in Figure 10.11.
- Pull carefully to separate the pieces of pipe.

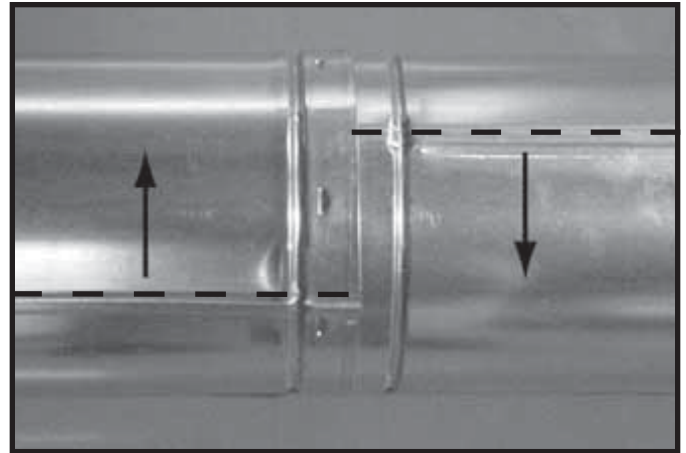

Figure 10.10 Rotate Seams for Disassembly

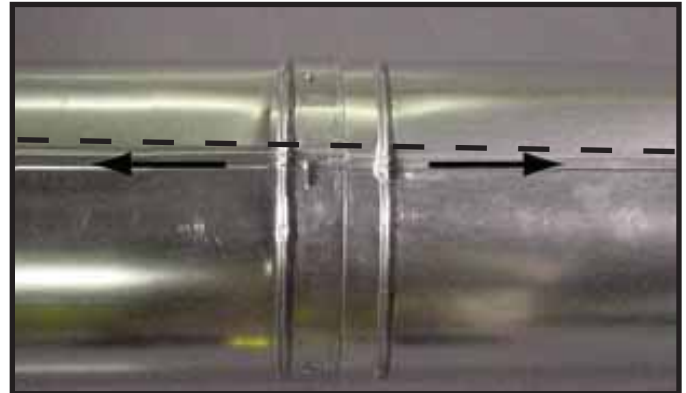

Figure 10.11 Align and Disassemble Vent Sections

## F. Install Decorative Ceiling Components (SLP only)

A decorative ceiling thimble can be installed on a flat ceiling through which the vent passes. The decorative ceiling thimble is used to cover the firestop.

- Seal the gap between the vent pipe and firestop using high temperature silicone to prevent cold air infiltration.
- Install the decorative ceiling thimble by sliding it up to the ceiling and attaching it using the provided screws.

A decorative cathedral ceiling support box can be installed on a cathedral ceiling through which the vent passes.

- Use a plumb-bob to mark the center line of the venting system on the ceiling and drill a small hole through the ceiling and roof at this point. Locate the hole and mark the outline of the cathedral ceiling support box on the outside roof.
- Remove shingles or other roof covering as necessary to cut the rectangular hole for the support box. Cut the hole 1/8 in. (3 mm) larger than the support box outline.
- Lower the support box through the hole in the roof until its bottom is at least 2 in. (51 mm) below the ceiling (Figure 10.12).
- Level the support box both vertically and horizontally and temporarily tack it in place through the inside walls into the roof sheathing.
- Use tin snips to cut the support box from the top corners down to the roof line and fold the resulting flaps to the roof. See Figure 10.13.
- Nail the flaps to the roof AFTER running a bead of non hardening sealant between the flaps and the roof.

**WARNING! Risk of Fire!** Clean out ALL materials from inside the support box and complete the vertical vent run and termination.

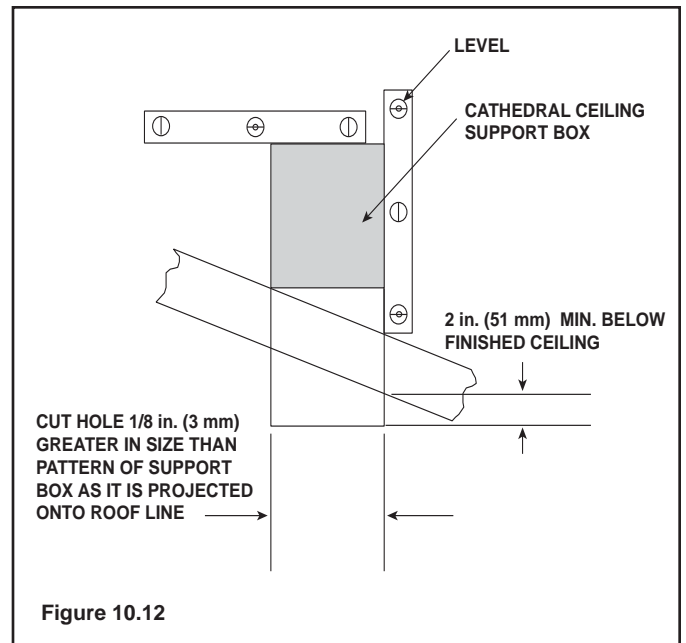

Figure 10.12

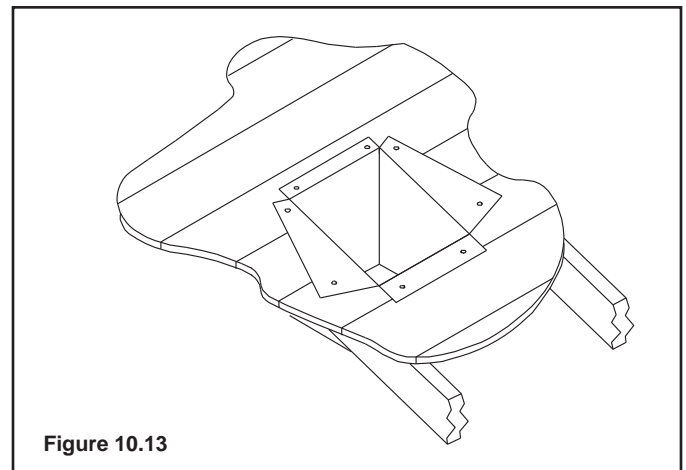
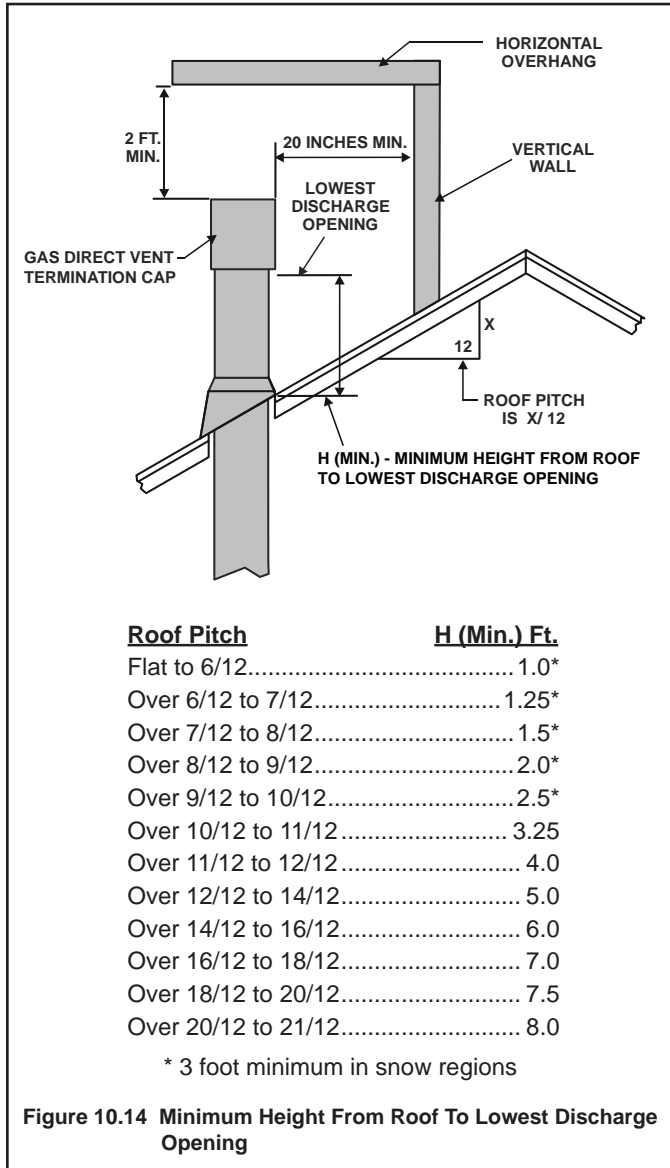

Figure 10.13



## G. Install Metal Roof Flashing

- See minimum vent heights for various pitched roofs (Figure 10.14) to determine the length of pipe to extend through the roof.
- Slide the roof flashing over the pipe sections extending through the roof as shown in Figure 10.15.



**NOTICE:** Failure to properly caulk the roof flashing could cause water entry.

- Caulk the gap between the roof flashing and the outside diameter of the pipe.
- Caulk the perimeter of the flashing where it contacts the roof surface. See Figure 10.15.

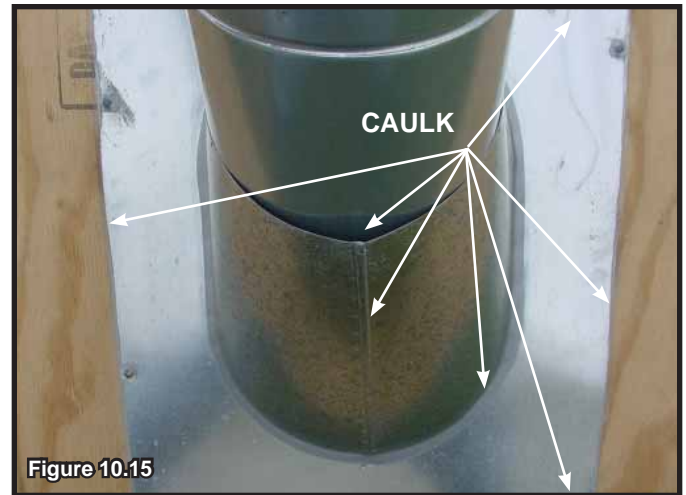

## H. Assemble and Install Storm Collar

**CAUTION! Risk of Cuts, Abrasions or Flying Debris.** Wear protective gloves and safety glasses during installation. Sheet metal edges are sharp.

- Connect both halves of the storm collar with two screws (see Figure 10.16).
- Wrap the storm collar around the exposed pipe section closest to the roof and align brackets. Insert a bolt (provided) through the brackets and tighten the nut to complete the storm collar assembly. Make sure the collar is tight against the pipe section.
- Slide the assembled storm collar down the pipe section until it rests on the roof flashing (see Figure 10.17).
- Caulk around the top of the storm collar (see Figure 10.18).

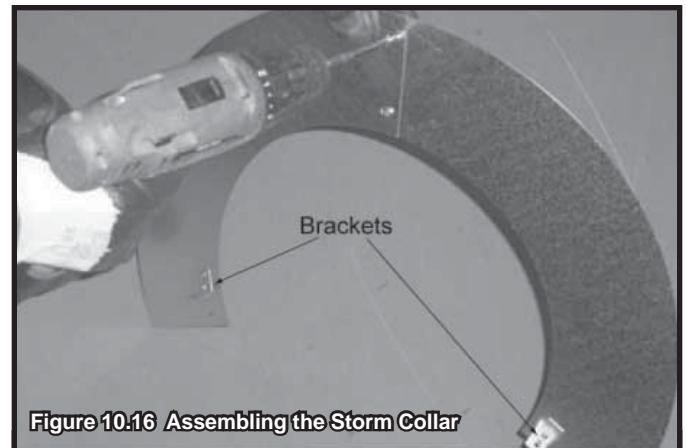



## I. Install Vertical Termination Cap

- Attach the vertical termination cap by sliding the inner collar of the cap into the inner flue of the pipe section while placing the outer collar of the cap over the outer flue of the pipe section.
- Secure the cap by driving three self-tapping screws (supplied) through the pilot holes in the outer collar of the cap into the outer flue of the pipe (see Figure 10.18).

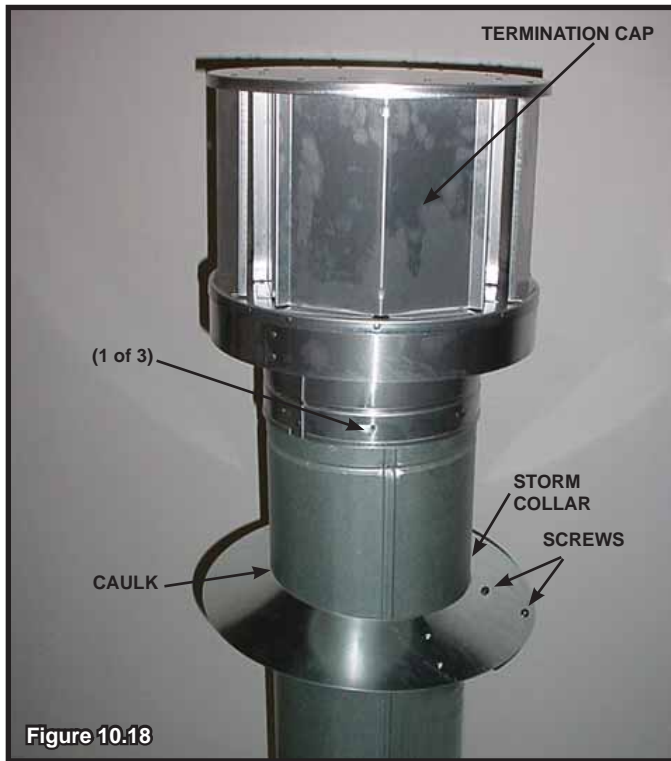

## J. Install Decorative Wall Components (SLP only)

A decorative wall thimble can be installed on wall through which the vent passes. The decorative wall thimble is used to cover the wall shield firestop.

- Slide the decorative wall thimble over the last section of horizontal pipe before connecting the termination cap to the pipe.
- Once the pipe section and the termination cap have been connected, slide the wall thimble up to the interior wall surface and attach with screws provided. See Figure 10.19.

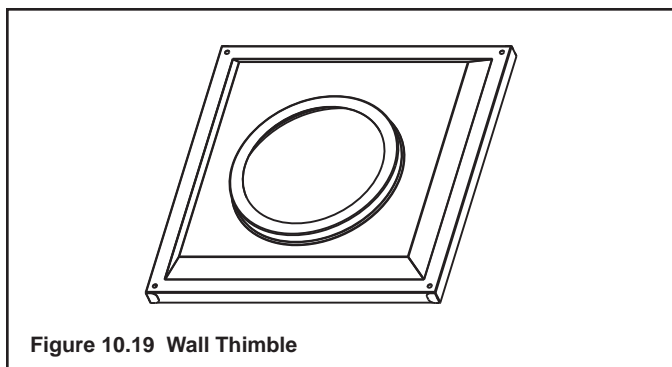

Figure 10.19 Wall Thimble

## K. Heat Shield Requirements for Horizontal Termination

**WARNING! Risk of Fire!** To prevent overheating and fire, heat shields must extend through the entire wall thickness.

- **DO NOT** remove the heat shields attached to the wall shield firestop and the horizontal termination cap (shown in Figure 10.25).
- Heat shields must overlap 1-1/2 in. (38 mm) minimum.

There are two sections of the heat shield. One section is factory-attached to the wall shield firestop. The other section is factory-attached to the cap. See Figure 10.20.

If the wall thickness does not allow the required 1-1/2 in. (38 mm) heat shield overlap when installed, an extended heat shield must be used.

- If the wall thickness is less than 4 in./102 mm (DVP) or 4-3/8 in./ 111 mm (SLP), the heat shields on the cap and wall shield firestop must be trimmed. A minimum 1-1/2 in. (38 mm) overlap **MUST** be maintained.
- Use an extended heat shield if the finished wall thickness is greater than 7-1/4 in. (184 mm).
- The extended heat shield may need to be cut to length maintaining sufficient length for a 1-1/2 in. (38 mm) overlap between heat shields.
- Attach the extended heat shield to either of the existing heat shields using the screws supplied with the extended heat shield. Refer to vent components diagrams in the back of this manual.
- Rest the small leg on the extended heat shield on top of the pipe section to properly space it from the pipe section.

**Important Notice:** Heat shields may not be field constructed.

## L. Install Horizontal Termination Cap (DVP and SLP Pipe)

**WARNING! Risk of Fire!** The telescoping flue section of the termination cap **MUST** be used when connecting vent.

- 1-1/2 (38 mm) minimum overlap of flue telescoping section is required.

Failure to maintain overlap may cause overheating and fire.

- Vent termination must not be recessed in the wall. Siding may be brought to the edge of the cap base.
- Flash and seal as appropriate for siding material at outside edges of cap.
- When installing a horizontal termination cap, follow the cap location guidelines as prescribed by current **ANSI Z223.1** and **CAN/CGA-B149** installation codes and refer to Section 6 of this manual.

**CAUTION! Risk of Burns!** Local codes may require installation of a cap shield to prevent anything or anyone from touching the hot cap.

**NOTICE:** For certain exposures which require superior resistance to wind-driven rain penetration, a flashing kit and HRC caps are available. When penetrating a brick wall, a brick extension kit is available for framing the brick.

**Note:** When using termination caps with factory-supplied heat shield attached, no additional wall shield firestop is required on the exterior side of a combustible wall.

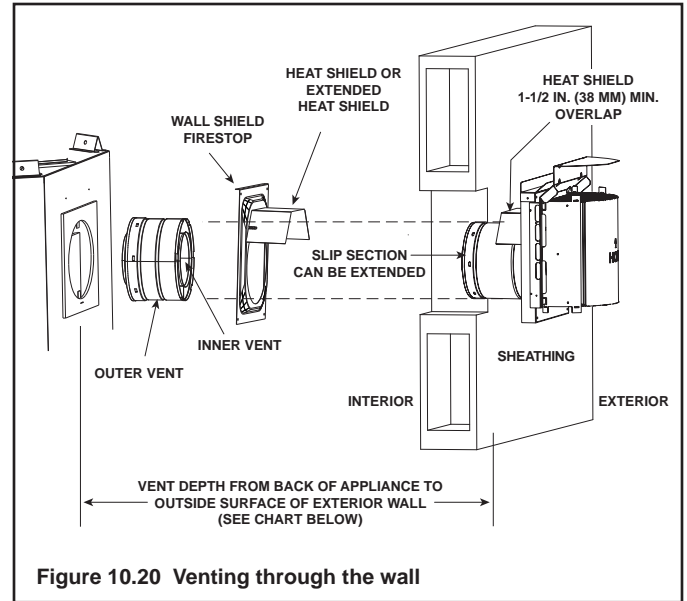

Figure 10.20 Venting through the wall

**Cap Specification Chart**  
(depth without using additional pipe sections)

36 inch Multisided Series	<b>DVP-TRAPK1 Top Vent Depth</b>	<b>DVP-TRAP1 Rear Vent Depth</b>	<b>DVP-TRAPK2 Top Vent Depth</b>	<b>DVP-TRAP2 Rear Vent Depth</b>
	2-7/8 in to 4-3/4 in	3-1/8 in. to 5 in.	5-1/4 in. to 9-1/4 in.	5-1/2 in. to 9-1/2 in.
	<b>DVP-HPC1 Top Vent Depth</b>	<b>DVP-HPC1 Rear Vent Depth</b>	<b>DVP-HPC2 Top Vent Depth</b>	<b>DVP-HPC2 Rear Vent Depth</b>
	2-7/8 in. to 5 in.	3-1/8 in. 5-1/4 in.	5 in. to 9-1/8 in.	5-1/4 in. to 9-1/2 in.

DVP-TRAP1 can adjust 1-1/2 in. (3-1/8 to 4-5/8 in.)

DVP-TRAP2 can adjust 4 in. (5-3/8 to 9-3/8)

DVP-HPC1 can adjust 2-1/8 in. (4-1/4 to 6-3/8)

DVP-HPC2 can adjust 4-1/8 in. (6-3/8 to 10-1/2)

# 11 Gas Information

## A. Fuel Conversion

- Make sure the appliance is compatible with available gas types.
- Conversions must be made by a qualified service technician using Hearth & Home Technologies specified and approved parts.

## B. Gas Pressure

- Optimum appliance performance requires proper input pressures.
- Gas line sizing requirements will be determined in ANSI Z223.1 National Fuel Gas Code in the USA and CAN/CGA B149 in Canada.
- Pressure requirements are:

Gas Pressure	Natural Gas	Propane
Minimum inlet pressure	5.0 in. w.c.	11.0 in. w.c.
Maximum inlet pressure	14.0 in. w.c.	14.0 in. w.c.
Manifold pressure	3.5 in. w.c.	10.0 in. w.c.

**WARNING! Risk of Fire/Explosion!** High pressure will damage valve. Low pressure may cause explosion.

- Verify inlet pressures. Verify minimum pressures when other household gas appliances are operating.
- Install regulator upstream of valve if line pressure is greater than 1/2 psig.

<b>⚠ WARNING</b>	
	<p>Fire Risk. Explosion Hazard. High pressure will damage valve.</p> <ul style="list-style-type: none"><li>• Disconnect gas supply piping <b>BEFORE</b> pressure testing gas line at test pressures above 1/2 psig.</li><li>• Close the manual shutoff valve <b>BEFORE</b> pressure testing gas line at test pressures equal to or less than 1/2 psig.</li></ul>

**Note:** Have the gas supply line installed in accordance with local codes, if any. If not, follow ANSI 223.1. Installation should be done by a qualified installer approved and/or licensed as required by the locality. (In the Commonwealth of Massachusetts installation must be performed by a licensed plumber or gas fitter).

**Note:** A listed (and Commonwealth of Massachusetts approved) 1/2 in. (13 mm) T-handle manual shut-off valve and flexible gas connector are connected to the 1/2 inch (13 mm) control valve inlet.

- **If substituting for these components, please consult local codes for compliance.**

## C. Gas Connection

- Refer to Reference Section 16 for location of gas line access in appliance.
- Gas line may be run through knockout(s) provided.
- The gap between supply piping and gas access hole may be caulked with caulk with a minimum of 300°F continuous exposure rating or stuffed with non-combustible, unfaced insulation to prevent cold air infiltration.
- Ensure that gas line does not come in contact with outer wrap of the appliance. Follow local codes.
- Pipe incoming gas line into valve compartment.
- Connect incoming gas line to the 1/2 in. (13 mm) connection on manual shutoff valve.

**WARNING! Risk of Fire or Explosion!** Support control when attaching pipe to prevent bending gas line.

- A small amount of air will be in the gas supply lines.

**WARNING! Risk of Fire or Explosion!** Gas build-up during line purge could ignite.

- Purge should be performed by qualified service technician.
- Ensure adequate ventilation.
- Ensure there are no ignition sources such as sparks or open flames.

Light the appliance. It will take a short time for air to purge from lines. When purging is complete the appliance will light and operate normally.

**WARNING! Risk of Fire, Explosion or Asphyxiation!** Check all fittings and connections with a non-corrosive commercially available leak-check solution. **DO NOT** use open flame. Fittings and connections could have loosened during shipping and handling.

**WARNING! Risk of Fire! DO NOT** change valve settings. This valve has been preset at the factory.

## D. High Altitude Installations

**NOTICE:** If the heating value of the gas has been reduced, these rules do not apply. Check with your local gas utility or authorities having jurisdiction.

When installing above 2000 feet elevation:

- In the USA: Reduce burner orifice 4% for each 1000 feet above 2000 feet.
- In the CANADA: Reduce burner orifice 10% for elevations between 2000 feet and 4500 feet. Above 4500 feet, consult local gas utility.

# 12 Electrical Information

## A. Wiring Requirements

**NOTICE:** This appliance must be electrically wired and grounded in accordance with local codes or, in the absence of local codes, with **National Electric Code ANSI/NFPA 70-latest edition** or the **Canadian Electric Code CSA C22.1**.

- Wire the appliance junction box to 110-120 VAC. This is required for use of optional accessories (standing pilot ignition) or proper operation of the appliance (IntelliFire ignition).
- A 110-120 VAC circuit for this product must be protected with ground-fault circuit-interrupter protection, in compliance with the applicable electrical codes, when it is installed in locations such as in bathrooms or near sinks.
- Low voltage and 110 VAC voltage cannot be shared within the same wall box.

**WARNING! Risk of Shock or Explosion! DO NOT wire 110V to the valve or to the appliance wall switch. Incorrect wiring will damage controls.**

## B. IntelliFire Ignition System Wiring

- Wire the appliance junction box to 110 VAC for proper operation of the appliance.

**WARNING! Risk of Shock or Explosion! DO NOT wire IPI controlled appliance junction box to a switched circuit. Incorrect wiring will override IPI safety lockout.**

- Refer to Figure 12.2, IntelliFire Pilot Ignition (IPI) Wiring Diagram.
- This appliance is equipped with an IntelliFire control valve which operates on a 3 volt system.
- Plug the 110 VAC plug from the WSK-MLT into the appliance junction box to supply power to the unit OR install two D cell batteries (not included) into the battery pack before use.

**NOTICE:** Batteries should not be placed in the battery pack while using the transformer. Remove batteries before using the WSK-MLT, and unplug the WSK-MLT before installing the batteries. Battery polarity must be correct or module damage will occur.

## C. Electrical Service and Repair

**WARNING! Risk of Shock! Label all wires prior to disconnection when servicing controls. Wiring errors can cause improper and dangerous operation. Verify proper operation after servicing.**

**WARNING! Risk of Shock! Replace damaged wire with type 105° C rated wire. Wire must have high temperature insulation.**

## D. Junction Box Installation

The junction box must be wired from the **INSIDE** of the appliance:

- Determine which side of the appliance the junction box is located on.
- Pull the electrical wires from outside the appliance through the knockout making sure to use a Romex connector to fasten the electrical wires to the unit.
- Pull enough wire into the valve compartment to easily reach the junction box location.
- Remove the screw attaching the junction box to the junction box bracket and set it aside.
- Route the wire through the knockout in the junction box bracket.
- Wire the junction box and reattach it to the bracket by inserting the tab in the slot and attaching with screw previously removed. Ensure that a Romex connector is used to attach the electrical wires to the junction box.

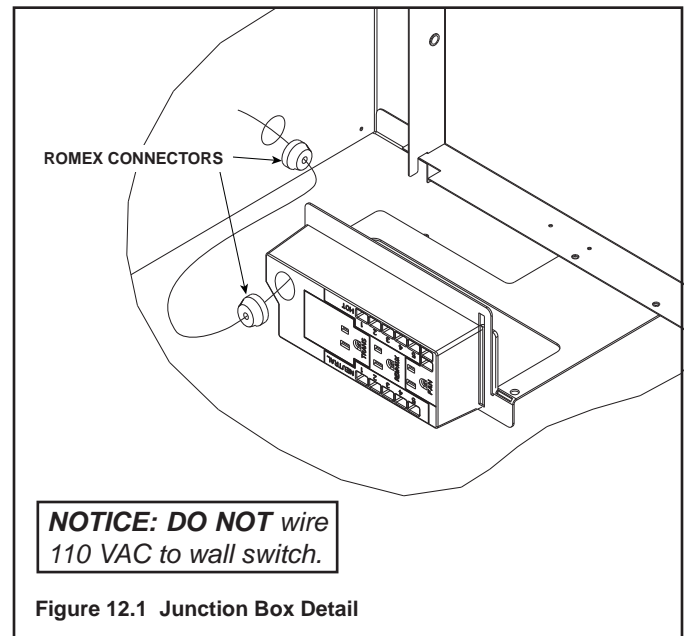

Figure 12.1 Junction Box Detail

## E. WSK-MLT Multifunction Wall Switch

The WSK-MLT multifunctional wall switch is designed to control flame height, blower speed and auxiliary functions on your gas fireplace. For models equipped with the Intellifire system (IPI), the cold climate function can control the pilot flame as well. The wall switch is equipped with thermostat functions which can automatically control the temperature in the room in which it is installed. An auxiliary function provides 110-120 VAC source for added features the fireplace may have installed. Electrical ratings for the control box are 110 VAC, 60 Hz, and is required for operation of this device.

### Precautions

This remote is tested and safe when installed in accordance with this installation manual. It is your responsibility to read all instructions before starting installation and to follow these instructions carefully during installation. Do not install any components that may be damaged. Do not modify, disassemble, or substitute any of the components included with this kit. Installation of this unit must be done by a qualified service technician.

Placement of this wall switch may affect performance or accuracy of the automatic (thermostat) control. An assessment of the space should be done prior to installation for optimal performance. See "Determine Location" for recommendations.

**Note:** The electrical junction box provided with the fireplace must be wired with 110 VAC before installing this kit.

All wiring should be done by a qualified electrician and shall be in compliance with local codes and with the **National Electric Code ANSI/NFPA No. 70- current** (in the United States), or with the current **CSA C22.1 CANADIAN ELECTRIC CODE** (in Canada).

### Determine Location

Determine the location for the wall switch. The chosen location should provide an accessible location in the same space as the gas fireplace. Never place this unit in a separate room. The control wire supplied with this unit is 12 ft (3.7 m) in length. The distance from the fireplace to the switch may be lengthened provided that the wire used never exceeds 50 ft, and that the distance from the fireplace to the switch never exceeds 30 ft.

The switch should be mounted into a listed electrical junction box. The junction box should be dedicated to this wall switch. Never install this wall switch into a junction box that is shared with other electrical service or devices. If possible, install this unit on an interior wall of the residence at a recommended height of 5 ft from the flooring. Should the switch be installed on an exterior wall, be certain wall insulation is kept intact and not damaged or dislodged during the installation of the electrical junction box.

For exterior wall installations, it is recommended that the junction box be sealed with caulking material. This will minimize heat loss through this location and improve the accuracy of the automatic (thermostat) operation.







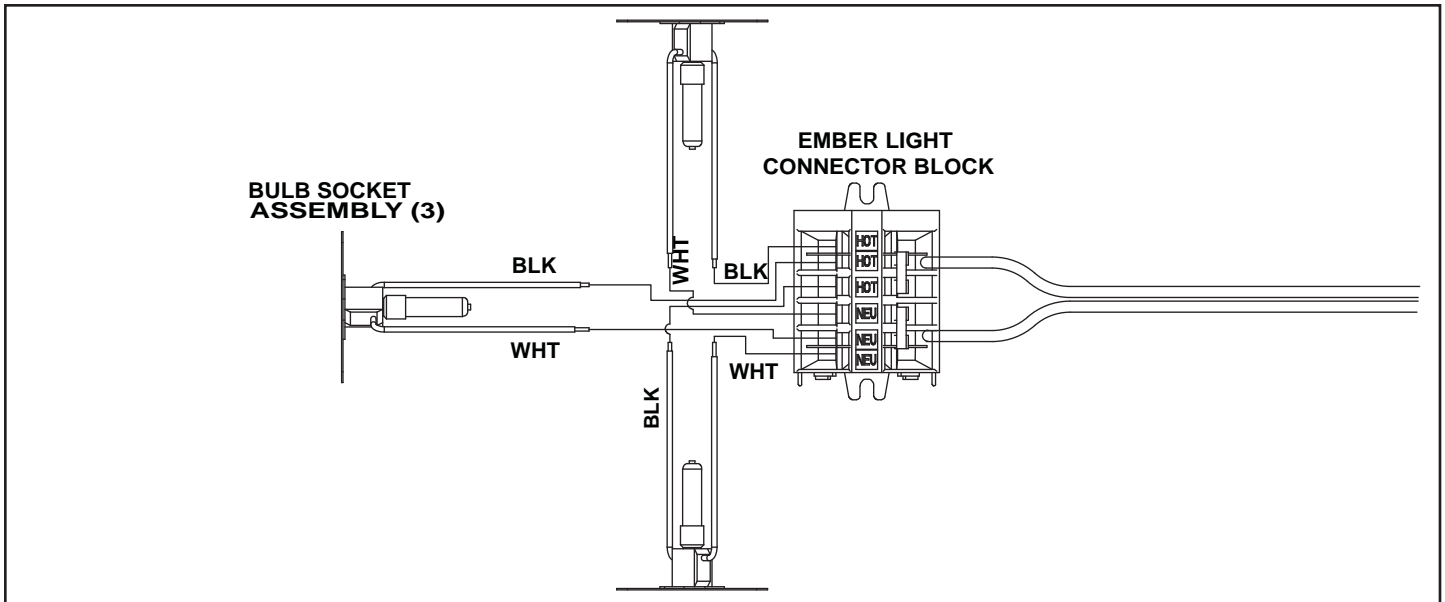

Figure 12.3 Ember Light Connector Block Detail

## F. Install the Flame Solenoid

- Remove the screw and knob from the variable regulator and discard.
- Remove the nut from the regulator and discard.
- Remove the bag containing a washer and blue and red plungers from the side of the flame control solenoid.
- Place washer on flame control solenoid.
- Insert the correct plunger (blue - natural gas, red - propane) into the flame control solenoid.
- Thread the flame control solenoid with correct plunger into the thread hole in the variable regulator. Turn into valve approximately two full turns. **Do not** tighten or damage may occur.
- Connect orange wires from control box to the flame control solenoid.

## G. Connect the Temperature Sensor Switch for Fan (optional)

- Find the two yellow wires from the WSK-MLT control box and disconnect them.
- Connect one yellow wire to one jumper wire hanging from the thermodisc.
- Connect the other yellow wire to remaining jumper wire hanging from thermodisc.
- See Figure 12.2 for wiring diagram.

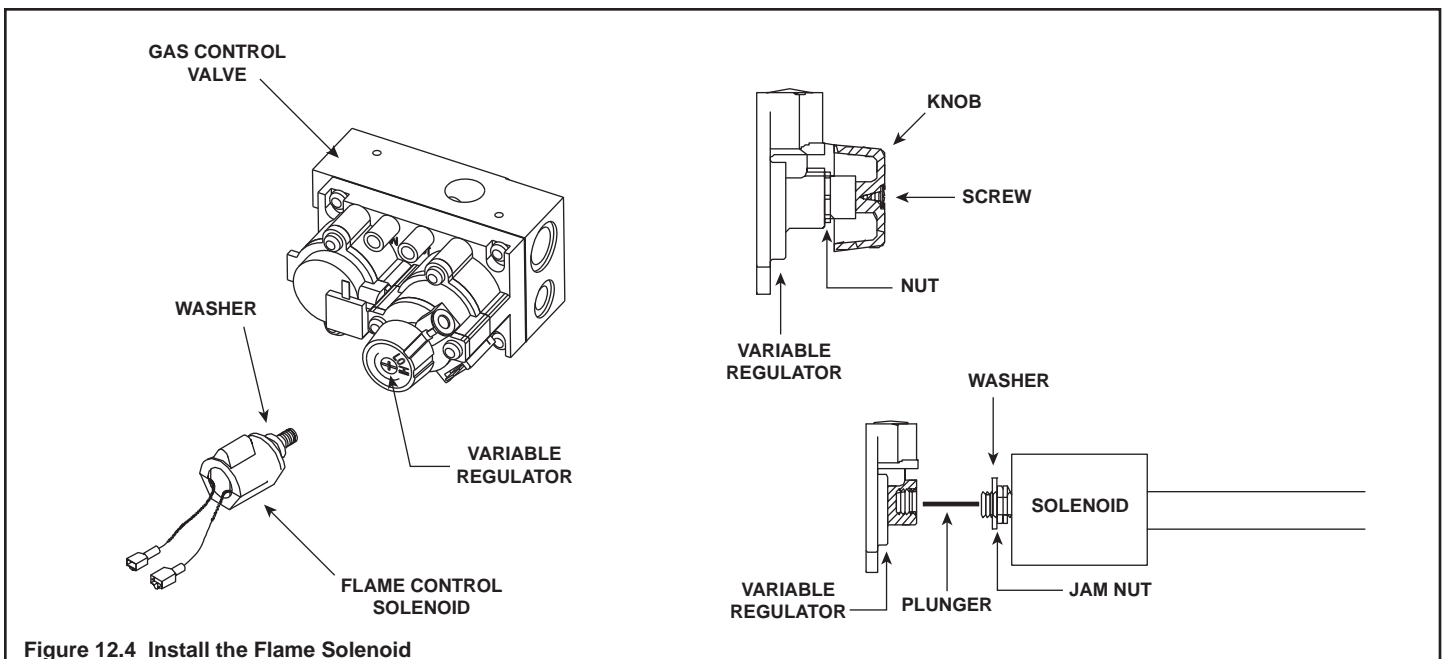

Figure 12.4 Install the Flame Solenoid

## H. WSK-MLT Operating Instructions

The ON/OFF rocker switch in the fireplace (located near the gas valve) must be in the "OFF" position for use with the WSK-MLT system. The ON/OFF rocker switch will NOT function with this device on Intellifire (IPI) models except during a power outage. The ON/OFF rocker switch will only be used to control the fireplace in a no-power condition.

After all connections are made and the control box is grounded, plug power cord into the fireplace junction box. The wall switch will be functional at this time.

For IPI system, refer to "Operation Under Battery Power" for instructions.

**Note:** The temperature displayed by the wall switch may take up to 30 minutes to stabilize on initial power-up.

**Note:** Check control box and assure switch is in the "OFF" position. This switch is only used on Intellifire (IPI) control systems under battery operation.

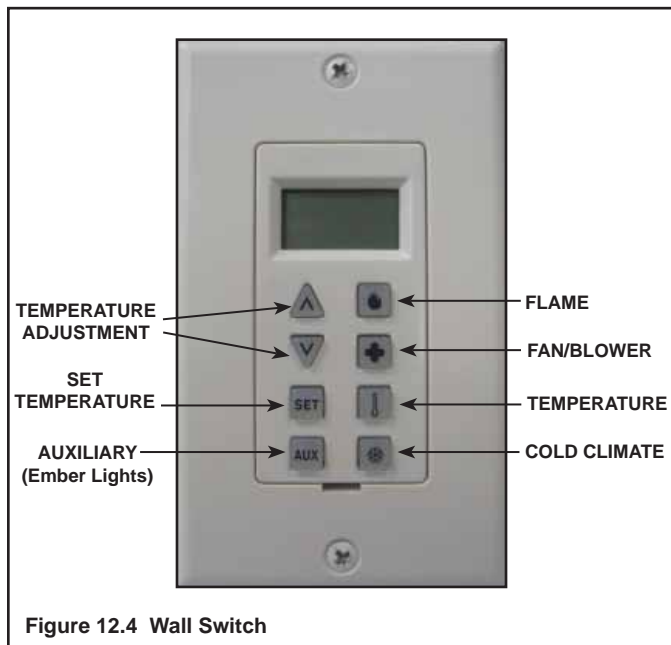

Figure 12.4 Wall Switch

## I. Setting Flame Height/Manifold Pressure

(To be done by a qualified service technician.) Upon initial power-up of this device, valve pressure must be set for flame adjustment.

- Loosen output pressure tap on valve and connect with pressure manometer.
- Press flame button once (see Figure 12.4); fireplace will light with flames on high.
- Turn solenoid clockwise to increase pressure, counterclockwise to decrease pressure until manifold pressure on high is 3.5 in. water column for natural gas (NG), 10.0 in. water column for propane (LP).
- Once pressure is achieved spin jam nut on solenoid step tight against regulator face to prevent rotation. Do not overtighten.
- Press flame button twice to turn fireplace off.
- Remove manometer tube and tighten or close pressure tap. Use a commercially available, non-corrosive leak check solution to carefully check the pressure tap for leaks. Be sure to rinse off all leak check solution following testing.

## J. Wall Switch Button Operation

### Flame Button

- Button Press: Unit On / Flames High, turns on auxiliary power
- Button Press: Flames Low
- Button Press: Unit Off / Flames Off, turns off auxiliary power

### Fan / Blower Button

- Button Press: Fan High ("3")
- Button Press: Fan Medium ("2")
- Button Press: Fan Low ("1")
- Button Press: Fan Off

### Temperature Button

- Button Press will toggle between Automatic and Manual Operation.
- Press and Hold the button for 3 seconds to toggle between Fahrenheit and Centigrade Temperature Display.

*Automatic Operation: Controller will monitor temperature and control unit according to the set point.*

*Manual Operation: Controller will not automatically change settings.*

### Set Temperature Button

- Button Press: Displays Set Point
- Use UP and Down Arrows to adjust set point
- Press Set Button to store new set point

Temperature Set Point can be adjusted between the ranges of 45-90° Fahrenheit or 7-32° Centigrade.

**Note:** The controller will turn off the fireplace at 2° F over set point and turn it back on at 2° F below set point.

### Up and Down Arrows

- Push to adjust set point temperature under automatic control.

### Auxiliary Button

- Button Press: Turns on ember lights
- Button Press: Turns off ember lights

Can be operated independently of all functions.

### Child Proof Mode

#### To Enter Child Proof Mode:

- Press the Up Arrow Button twice and Down Arrow Button once. The unit will send out three beeps and an indicator in the LCD panel will show that the child proof is on.

#### To Leave Child Proof Mode:

- Press the Up Arrow Button twice and Down Arrow Button once. The unit will send out three beeps and the indicator in the LCD panel showing that child proof is on will disappear.

**Note:** When in Child Proof Mode, only the arrow buttons will have functionality. Unit can enter Child Proof when the fireplace is on or off.

### Cold Climate Button

- Button Press: Turns on Climate Control
- Button Press: Turns off Climate Control

This allows the pilot flame to stay lit when activated. A benefit of this is reduced condensation on the glass at start-up in colder climate conditions.

### Operation Under Battery Power

A switch on the control box allows for battery power under no-power conditions (see Figure 12.5). By controlling the power supply with this switch, the batteries are supplying power only when needed, thus extending battery life. The switch also provides a convenient means for switching to battery power should there be a loss of 110 VAC power to the control box.

- In the event of a power failure, switch the battery operation switch to the "Battery ON" position.
- The fireplace can now be turned on and off with the ON/OFF rocker switch located near the gas valve.
- The wall switch functions will not operate under battery power.
- Under battery control the only available function is flame "ON" and "OFF" in the high position.
- To maximize battery life, and to restore full function capability of the wall switch, flip switch to "OFF" position after 120 VAC power is restored.

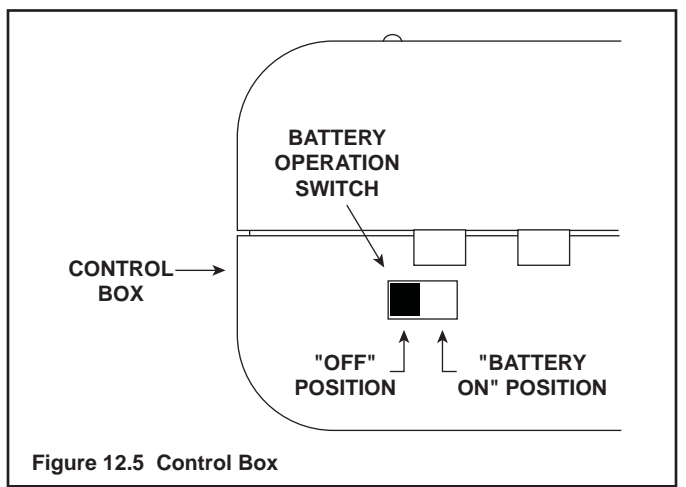



Figure 12.5 Control Box

# 13 Finishing

## A. Splatter Guard

The splatter guard is a piece of corrugated material used to protect the appliance during the installation process before finishing work on the whole hearth is complete.

Splatter guards must be removed before appliance is fired.

	<b>WARNING</b>
	Risk of Fire
	<ul style="list-style-type: none"><li>• Splatter guard must be removed before lighting appliance.</li><li>• Before splatter guard is installed: Close ball valve to prevent accidental lighting.</li></ul>

Step 1. Turn off gas to valve. Red gas shutoff knob is located on ball valve. Disconnect the WSK-MLT from the junction box. See Figure 13.1.



Figure 13.1 Preparation to Install Splatter Guard

### To install the Splatter Guard:

Step 2. Crease flap on top side of splatter guard using the scored line as the guide. See Figure 13.2.



Figure 13.2 Folding Top Flap

Step 3. Crease flaps on left and right sides of splatter guard using the scored line as the guide. See Figure 13.2.



Figure 13.3 Folding of Right and Left Sides of Splatter Guard

Step 4. Center the splatter guard in front of the unit as shown in Figure 13.3. Place the splatter guard in the unit by guiding the top flap into proper position and then continuing to guide the tabs on the side flaps into the top slot on the left and right sides of the appliance. The top slot is indicated in Figure 13.5 Take care not to bend or break off the tabs.



Figure 13.4 Installation of Splatter Guard

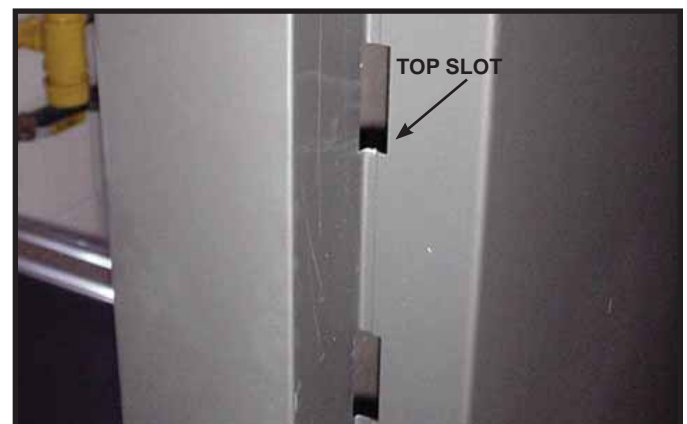

Figure 13.5 Top slot



Step 5. Fold bottom flap along score line as indicated in Figure 13.6 and tuck into valve access area of appliance. Splatter guard should fit securely on front of unit.



Figure 13.6 Folding Bottom Flap



Figure 13.7 Prepare to Open Lower Access Panel

Step 6. To open lower access panel of splatter guard, place one hand above score line and place two fingers from other hand in the round holes on the front of the splatter guard. See Figure 13.7. Pull out and fold up the panel as shown in Figure 13.8. Disengage the tabs on left and right bottom of splatter guard and fit them into the square holes. The tabs are now inside the front of the splatter guard; carefully bend them down. See Figure 13.9.



Figure 13.8 Opening Lower Access Panel



Figure 13.9 Securing Tabs Inside Front of Splatter Guard

Once plumbing and wiring are complete on the fireplace, the lower access panel may be closed until the time that the splatter guard must be removed for firing the appliance.



Figure 13.10 Splatter Guard with Lower Access Panel Open

#### To Close the Lower Access Panel:

Carefully disengage the tabs from the square holes and bend the access panel to its original position. Bend the center bottom flap and insert it into the bottom of the appliance.



Figure 13.11 Splatter Guard with Lower Access Panel Closed

#### To Remove the Splatter Guard:

Carefully grab splatter guard on or near the vertical center on the left and right sides. Pull outward gently, but firmly, taking care not to tear or remove the inserted tabs.

## B. Mantel and Wall Projections

**WARNING! Risk of Fire!** Comply with all minimum clearances as specified. Framing closer than the minimums listed must be constructed entirely of noncombustible materials (i.e., steel studs, concrete board, etc.) Failure to comply could cause fire.

### See-Through Combustible Mantel

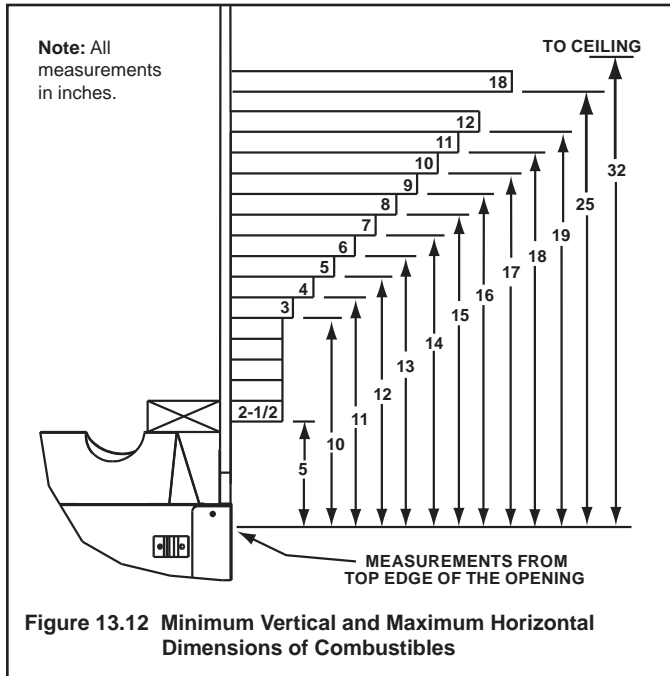

### See-Through Non-Combustible Mantel

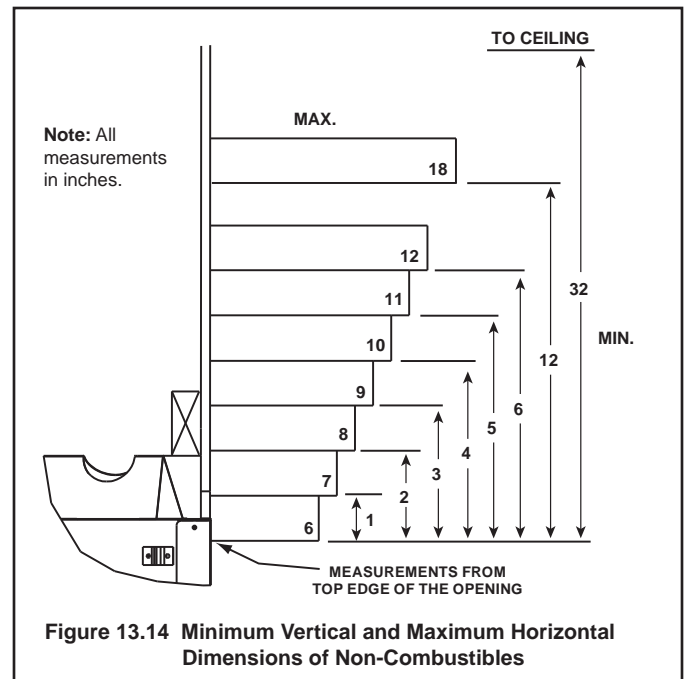

### PIER Combustible Mantel

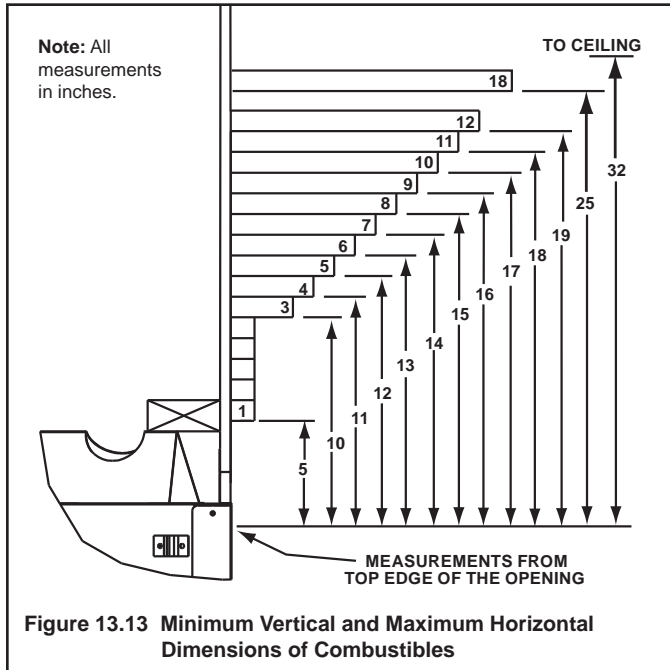

### PIER Non-Combustible Mantel

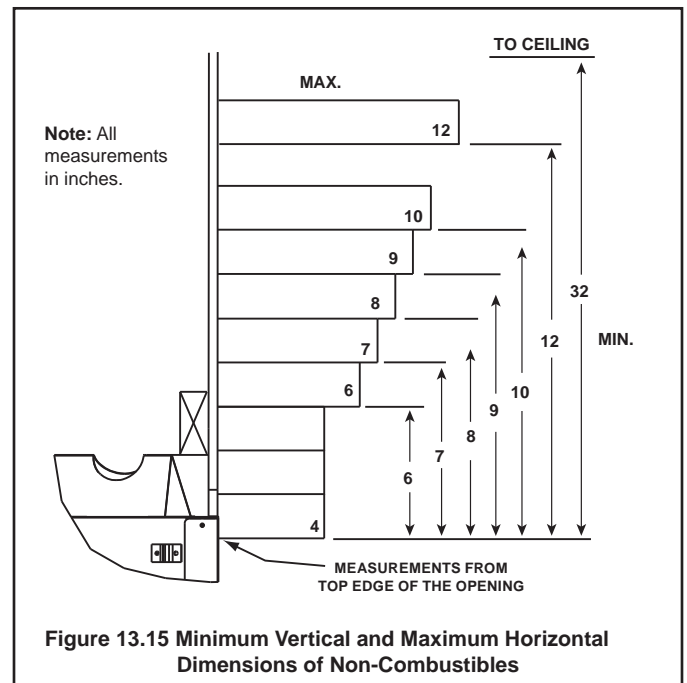



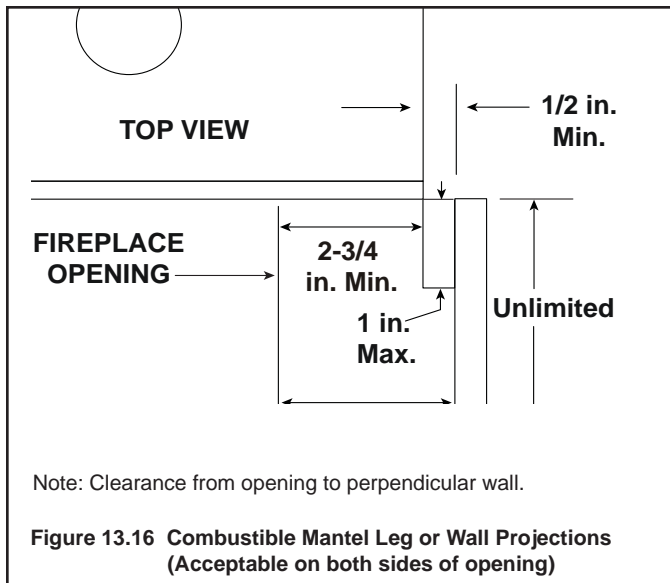

### C. Facing Material

- Metal front faces may be covered with non-combustible materials only.
- Facing and/or finishing materials must not interfere with air flow through louvers, operation of louvers or doors, or access for service.
- Facing and/or finishing materials must never overhang into the glass opening.
- Observe all clearances when applying combustible materials.
- Seal joints between the finished wall and appliance top and sides using a 300 °F minimum sealant. Refer to Figure 13.17.

**WARNING! Risk of Fire! DO NOT** apply combustible materials beyond the minimum clearances. Comply with all minimum clearances to combustibles as specified in this manual. Overlapping materials could ignite and will interfere with proper operation of doors and louvers.

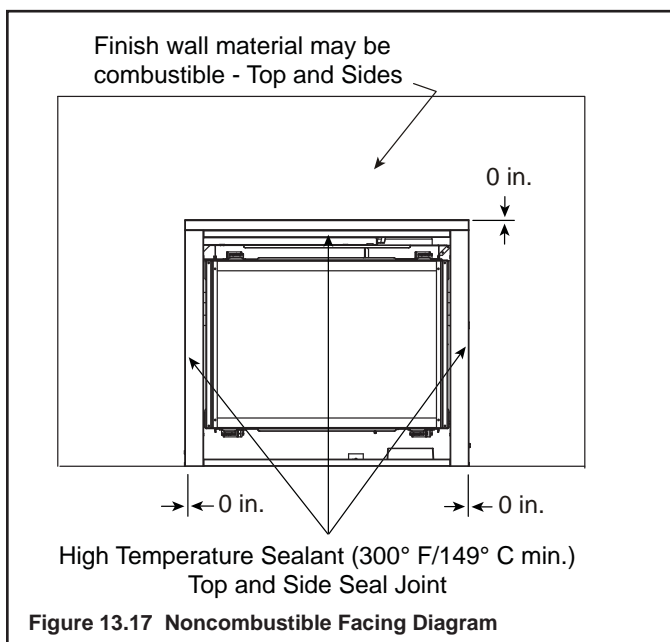

## D. Finishing Material

Only doors certified for use with this appliance model may be used. Contact your dealer for a list of doors that may be used. Once you have determined what kind of door and finishing material is going to be used on the fireplace, you may use the table below which shows the door models and the finishing material thickness allowed. For an inside fit there is an available template to assist with sizing the finishing material.

### ST-36TR-IPI

DOOR	FIT	FINISH MATERIAL MAXIMUM THICKNESS	SEE FIGURE
Aero	Inside	Any	13.18
Folio	Inside	Any	13.18
Arcadia	Overlap	1 inch	13.19
	Inside	Any	13.20
Halston	Overlap	1 inch	13.19
	Inside	1 inch - 2 inch	13.21
Chateau	Overlap	1 inch	13.19
	Inside	Any	13.20
Valencia	Overlap	1 inch	13.19
	Inside	Any	13.20
Galleria	Overlap	1 inch	13.19
	Inside	1 inch - 2 inch	13.21

### PIER-36TR-IPI

DOOR	FIT	FINISH MATERIAL MAXIMUM THICKNESS	SEE FIGURE
Aero	Inside	Any	13.22
Chateau	Inside	Any	13.22
Arcadia	Inside	Any	13.22

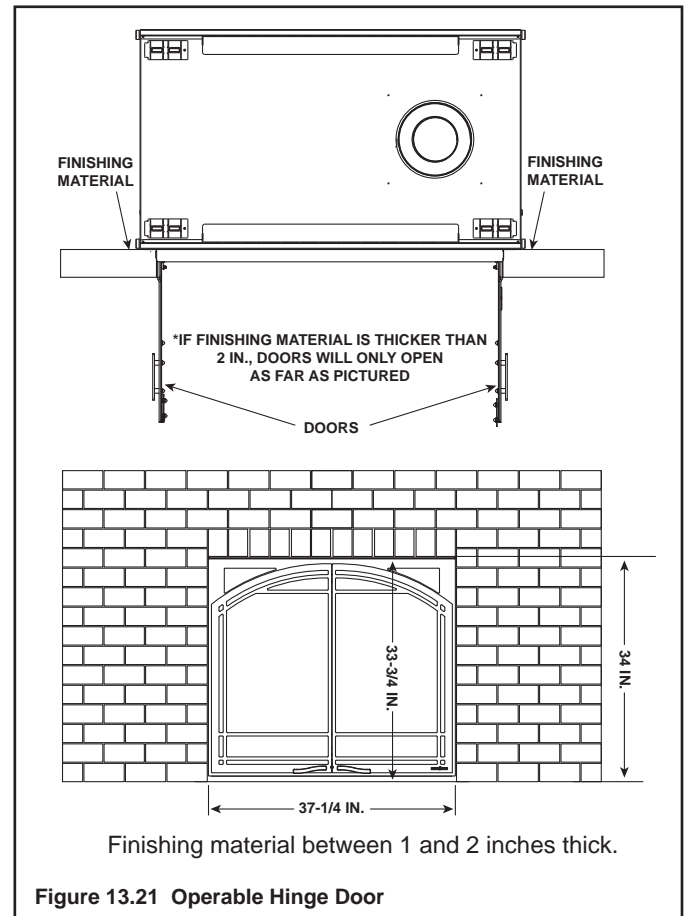
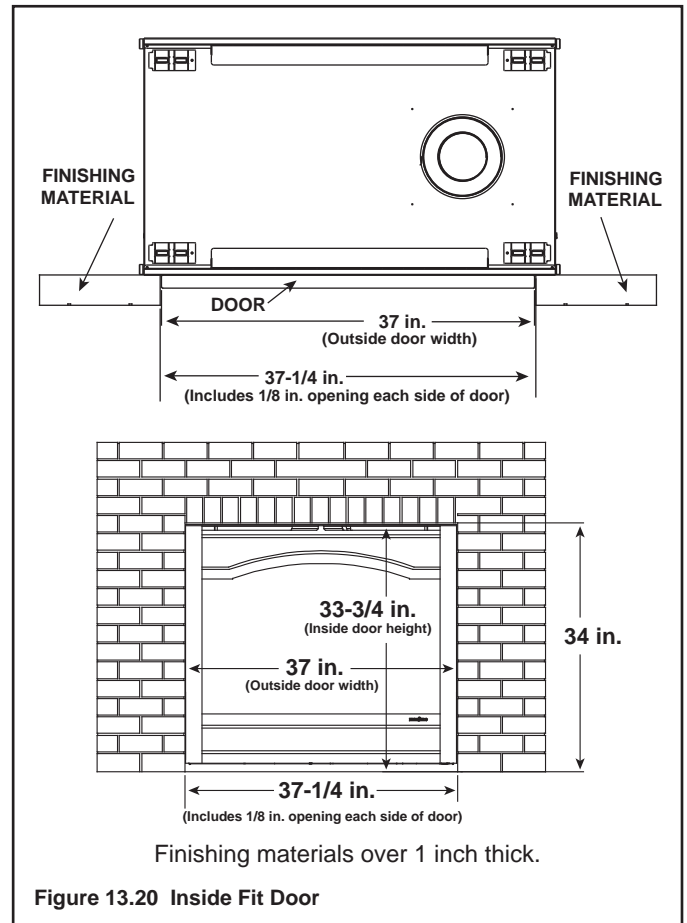
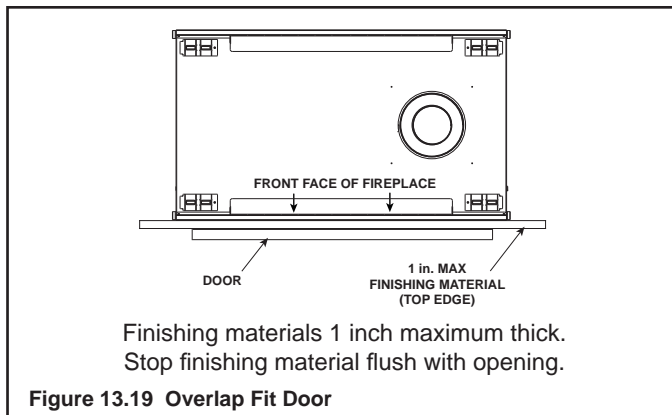
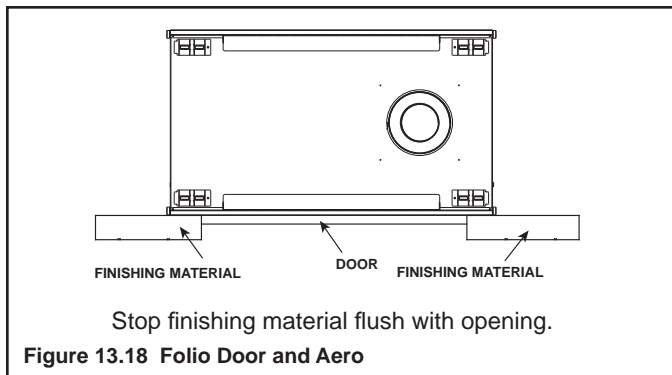

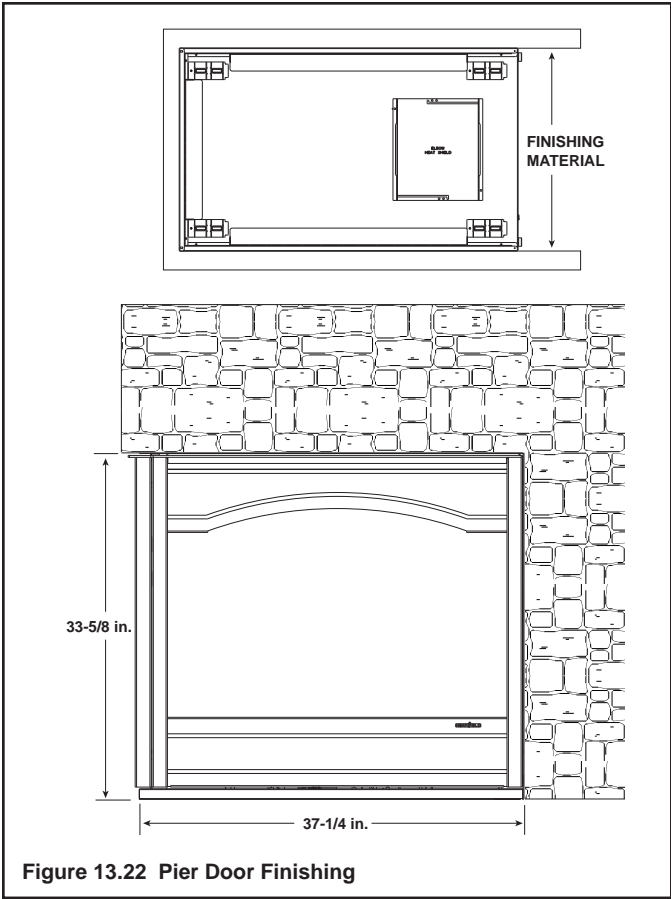

Figure 13.22 Pier Door Finishing

## E. Elevated Hearth Systems

Use the table below to identify the hearth system that will be used. The table will also help identify effects on the various dimensions. Some hearth systems will elevate the appliance off the floor at a given dimension. For example, if appliance will be used with a Kenwood Cabinet with Base, the appliance will be elevated 9-1/4 inches. The 9-1/4 inch elevation will also have to be added to the following: Extension Wall Hole referenced in Figure 8.2 (Exterior Wall Hole) and Rough Opening Height (header height) referenced in Figure 5.2. Note: Finished floor thickness should also be considered when determining installation dimensions.

MODEL	DESCRIPTION	PART #	ELEVATED APPLIANCE DIMENSION See Note 1	MARBLE LEG CUT LENGTH See Note 2
	KENWOOD MANTEL	AFKDMPB	0 (See Note 3)	27-3/8 in.
	KENWOOD MANTEL W/ BASE	AFKDMPB W/ HTKDMPB	9-1/4 in.	29-3/8 in.
	LAURENT SURROUND	LAURENT-36	1-1/2 in.	N/A
	CAMDEN SURROUND	CAM36PG	0	N/A
	CAMDEN SURROUND W/HEARTH	CAM36PGH	1-3/4 in.	N/A
	CAMDEN SURROUND W/MANTEL	CAMM36PG	0	N/A
	CAMDEN SURROUND W/MANTEL & HEARTH	CAMM36PGH	1-3/4 in.	N/A
	ESSEX SURROUND	ESSEX36PG	0	N/A
	ESSEX SURROUND W/HEARTH	ESSEX36PGH	1-3/4 in.	N/A
	ESSEX SURROUND W/MANTEL	ESSEXM36PG	0	N/A
	ESSEX SURROUND W/MANTEL & HEARTH	ESSEXM36PGH	1-3/4 in.	N/A
	MONROE SURROUND	MON36PG	0	N/A
	MONROE SURROUND W/HEARTH	MON36PGH	1-3/4 in.	N/A
	MONROE SURROUND W/MANTEL	MONM36PG	0	N/A
	MONROE SURROUND W/MANTEL & HEARTH	MONM36PGH	1-3/4 in.	N/A

**Note 1. Add dimensions to Exterior Wall Hole (Figure 8.2) and Rough Opening Height (Figure 5.2).**

**Note 2. Verify Marble Cut Lengths on site prior to cutting.**

**Note 3. Dimensions assume use of a 3/4 in. Hearth Pad.**

# 14 Appliance Setup

## A. Remove Fixed Glass Assembly

See Section 14G.

## B. Remove the Shipping Materials

Remove shipping materials from inside or underneath the firebox.

## C. Clean the Appliance

Clean/vacuum any sawdust that may have accumulated inside the firebox or underneath in the control cavity.

## D. Accessories

Install approved accessories per instructions included with accessories. Contact your dealer for a list of approved accessories.

**WARNING! Risk of Fire and Electric Shock!** Use ONLY *Hearth & Home Technologies-approved optional accessories with this appliance. Using non-listed accessories could result in a safety hazard and will void the warranty.*

## E. Lava Rock/Teco-Sil and Glowing Ember Placement

**Prepare Electric Ember Bed and Lava Rock.** The electric ember bed must be prepared before the logs are set up. See Figure 14.1.



Figure 14.1 Teco-Sil

Start by applying the glass ember rock (Teco-Sil) to the base pan as shown in Figure 14.2.



Figure 14.2 Teco-Sil Placement

Place a thin layer and follow the pattern on the base pan as shown in Figure 14.3.

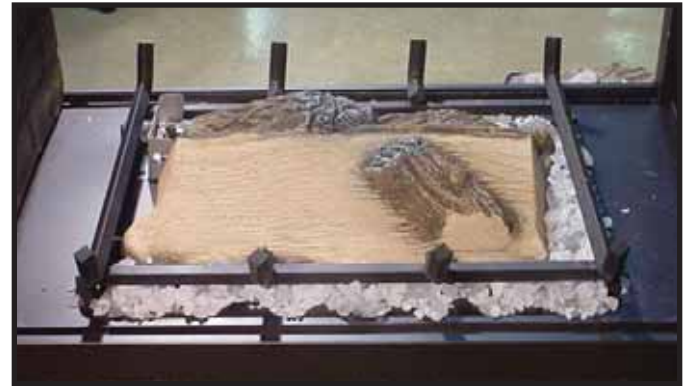

Figure 14.3 Teco-Sil Placement

Apply lava rock. The lava rock should cover the remaining base pan area. See Figure 14.4. Do not put lava rock on top of the glass ember rock (Teco-Sil).



Figure 14.4 Lava Rock Placement

Turn on the electric ember lights and paint the glass ember rock (Teco-Sil) to the desired darkness. See Figure 14.5.



Figure 14.5 Painting Teco-Sil

Make sure to paint the glass from both sides as shown in Figure 14.6.



Figure 14.6 Painting Teco-Sil

**WARNING! Risk of Explosion!** Follow ember placement instructions in manual. DO NOT place embers directly over burner ports. Replace ember material annually. Improperly placed embers interfere with proper burner operation.

#### Placing the Ember Material

Ember material is shipped with this gas appliance. To place the ember material:

- Embers CANNOT be placed directly over ports. Care should be taken not to cover the lighting trail of ports (from back to front).
- When placing Glowing Embers® onto the burner care should be taken so that the ports are not covered. Place the dime-size ember pieces just in front of the port trail, but not on or in between the ports (see Figure 14.7). Failure to follow this procedure will likely cause lighting and sooting problems.
- Save the remaining ember materials for use during appliance servicing. The embers provided should be enough for 3 to 5 applications.



Figure 14.7 Placement of Embers



F. Install the Log Assembly

Log Set Assembly: LOGS-MSR

Models: PIER-HV, ST-HV, LCOR-HV, RCOR-HV  
ST-36TR, PIER-36TR, TWILIGHT-II-B

PIER-HV, ST-HV, RCOR-HV, ST-36TR, PIER-36TR, TWILIGHT-II-B

(See page 4 for LCOR-HV)



**CAUTION:** Logs are fragile! Carefully remove the logs from the packaging. Remove the cardboard support from inside of fireplace.

**STEP 1.** Before positioning the logs, refer to the installation manual for electric ember set-up and ember placement.

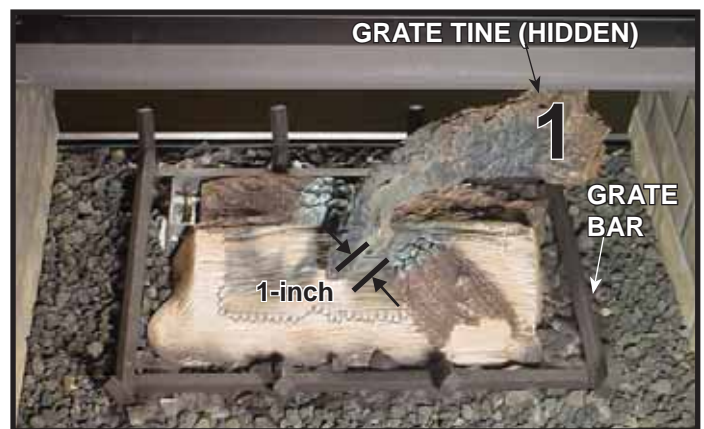

**STEP 2.** LOG #1 (SRV2005-701): Use the indent on the bottom side of the log to position the large end of the log onto the grate bar as shown. Slide the log back until the indent engages the grate tine as shown above. Position the thin end of log #1 one inch from port pattern as shown.

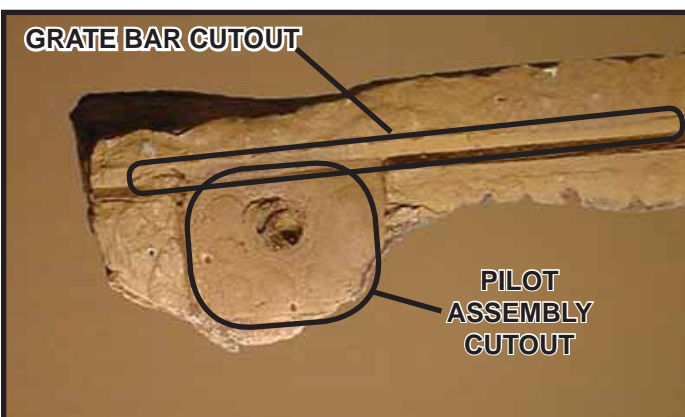

**STEP 3.** LOG #2 (SRV2005-700): Position log #2 on the left grate bar and the pilot assembly. Use the cut out notches on the log to position it as shown.

2005-937F 9/08

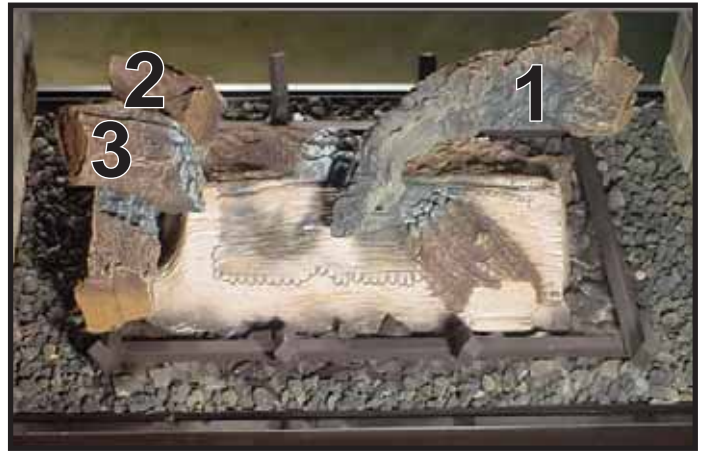

STEP 4. LOG #3 (SRV2005-702): Position log #3 as shown by leaning it against log #2 and resting the other end on the peak of the burner. **DO NOT** cover any port holes.

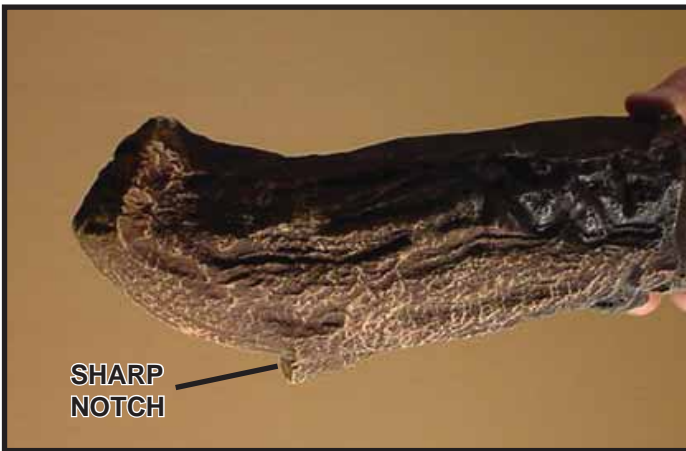

STEP 5. LOG #4 (SRV2005-703): Locate the sharp notch on log #4 against the grate tine as shown. The smooth cutout on the bottom of log #4 should rest on the burner surface. The side of Log #4 must be 3/4 inch from the nearest port hole on the right side of log #4. **DO NOT** cover any port holes.



STEP 6. LOG #5 (SRV2005-704): Using the sharp notch on the heavy end of log #5, align it on the grate tine and set it on the flat area of log #4 as shown.



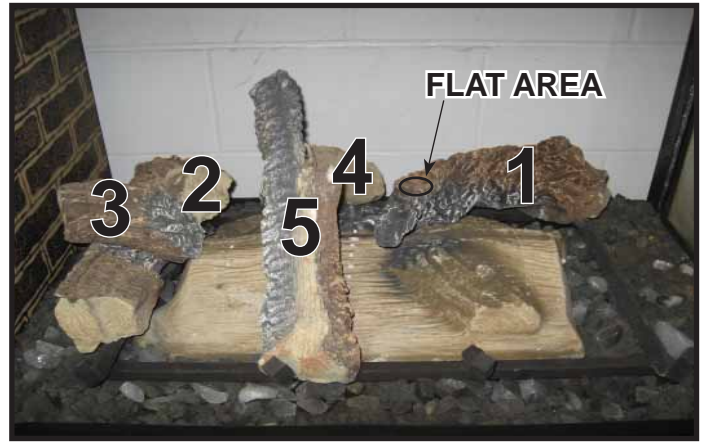

**STEP 7. LOG #6 (SRV2005-705):** Locate the notch on log #6 and place it against the front right grate tine. Set the other end of the log so it rests on the flat area of log #1. The orientation of log #6 in relation to the grate tine is shown below.



Log Assembly Installed.

## G. Fixed Glass Assembly

**WARNING! Risk of Asphyxiation!** Handle fixed glass assembly with care. Inspect the gasket to ensure it is undamaged and inspect the glass for cracks, chips or scratches.

- **DO NOT** strike, slam or scratch glass.
- **DO NOT** operate fireplace with glass removed, cracked, broken or scratched.
- Replace as a complete assembly.

## Removing Fixed Glass Assembly

- Pull the four glass latches out of the grooves on the glass frame top and bottom.
- Remove the glass door from the appliance.
- Multiple sides may be able to be removed based upon model.

## Replacing Fixed Glass Assembly

- Replace the glass door on the appliance.
- Pull out the four glass latches and place in the grooves on the glass frame top and bottom.
- Make sure all sides are replaced properly.

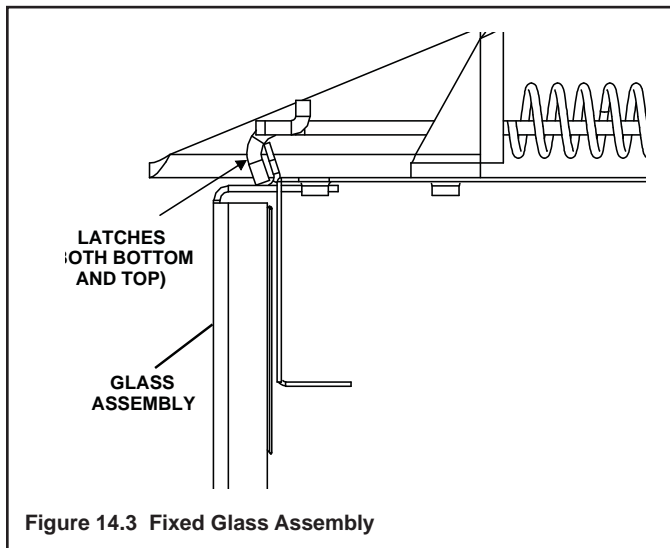

## H. Install Trim Kits and Surrounds

- Install optional trim kits and/or surrounds using the instructions included with the accessory.
- Use non-combustible materials to cover the gap between the sheet rock and the appliance (if desired).

## I. Air Shutter Setting

This appliance has an adjustable air shutter (which controls the primary air) factory set for the minimum vertical vent run. If your installation has more than the minimum required vertical vent length, adjustment of the air shutter may be necessary to obtain optimal flame appearance. **This should be adjusted by a qualified installer at the time of installation.**

**NOTICE:** If sooting occurs, provide more air by opening the air shutter.

## Air Shutter Settings

	NG	LP
Burner	3/8 in.	Fully open

# 15 Troubleshooting

With proper installation, operation, and maintenance your gas appliance will provide years of trouble-free service. If you do experience a problem, this troubleshooting guide will assist a qualified technician in the diagnosis of a problem and the corrective action to be taken. This troubleshooting guide can only be used by a qualified technician. Contact your dealer to arrange a service call by a qualified technician.

## A. IntelliFire Ignition System

Symptom	Possible Cause	Corrective Action
1. Pilot won't light. The ignitor/module makes noise, but no spark.	a. Incorrect wiring.	Verify "S" wire (white) for sensor and "I" wire (orange) for ignitor are connected to correct terminals on module and pilot assembly.
	b. Loose connections or electrical shorts in the wiring.	Verify no loose connections or electrical shorts in wiring from module to pilot assembly. Verify connections underneath pilot assembly are tight; also verify connections are not grounding out to metal chassis, pilot burner, pilot enclosure, mesh screen if present, or any other metal object.
	c. Ignitor gap is too large.	Verify gap of igniter to right side of pilot hood. The gap should be approximately .17 in. or 1/8 in. (3 mm).
	d. Module.	Turn ON/OFF rocker switch or wall switch to OFF position. Remove ignitor wire "I" from module. Place a grounded wire about 3/16 in. (5 mm) away from "I" terminal on module. Place ON/OFF rocker switch or wall switch in ON position. If there is no spark at "I" terminal module must be replaced. If there is a spark at "I" terminal, module is fine. Inspect pilot assembly for shorted sparker wire or cracked insulator around electrode. Replace pilot if necessary.
2. Pilot won't light, there is no noise or spark.	a. No power or transformer installed incorrectly.	Verify that transformer is installed and plugged into module. Check voltage of transformer under load at spade connection on module with ON/OFF switch in ON position. Acceptable readings of a good transformer are between 3.2 and 2.8 volts AC.
	b. A shorted or loose connection in wiring configuration or wiring harness.	Remove and reinstall the wiring harness that plugs into module. Verify there is a tight fit. Verify pilot assembly wiring to module. Remove and verify continuity of each wire in wiring harness. Replace any damaged components.
	c. Improper wall switch wiring.	Verify that 110/VAC power is "ON" to junction box.
	d. Module not grounded.	Verify black ground wire from module wire harness is grounded to metal chassis of appliance.
	e. Module.	Turn ON/OFF rocker switch or wall switch to OFF position. Remove ignitor wire "I" from module. Place ON/OFF rocker switch or wall switch in ON position. If there is no spark at "I" terminal module must be replaced. If there is a spark at "I" terminal, module is fine. Inspect pilot assembly for shorted sparker wire or cracked insulator around electrode.
3. Pilot sparks, but Pilot will not light.	a. Gas supply.	Verify that incoming gas line ball valve is "open". Verify that inlet pressure reading is within acceptable limits, inlet pressure must not exceed 14 in. W.C.
	b. Ignitor gap is incorrect.	Verify that spark gap from ignitor to pilot hood is .17 in. or 1/8 in (3 mm).
	c. Module is not grounded.	Verify module is securely grounded to metal chassis of appliance.
	d. Module voltage output / Valve/Pilot solenoid ohms readings.	Verify battery voltage is at least 2.7 volts. Replace batteries if voltage is below 2.7.

## IntelliFire Ignition System - (continued)

Symptom	Possible Cause	Corrective Action
4. Pilot lights but continues to spark, and main burner will not ignite. (If the pilot continues to spark after the pilot flame has been lit, flame rectification has not occurred.)	a. A shorted or loose connection in flame sensing rod.	Verify all connections to wiring diagram in manual. Verify connections underneath pilot assembly are tight. Verify connections are not grounding out to metal chassis, pilot burner, pilot enclosure or screen if present, or any other metal object.
	b. Poor flame rectification or contaminated flame sensing rod.	With fixed glass assembly in place, verify that flame is engulfing flame sensing rod on left side of pilot hood. Flame sensing rod should glow shortly after ignition. Verify correct pilot orifice is installed and gas inlet is set to pressure specifications. Polish flame-sensing rod with fine steel wool to remove any contaminants that may have accumulated on flame sensing rod. ←
	c. Module is not grounded.	Verify module is securely grounded to metal chassis of appliance. Verify that wire harness is firmly connected to the module.
	d. Damaged pilot assembly or contaminated flame sensing rod.	Verify that ceramic insulator around the flame sensing rod is not cracked, damaged, or loose. Verify connection from flame sensing rod to white sensor wire. Polish flame-sensing rod with fine steel wool to remove any contaminants that may have accumulated on flame sensing rod. Verify continuity with a multimeter with ohms set at lowest range. Replace pilot if any damage is detected. ←
	e. Module.	Turn ON/OFF rocker switch or wall switch to OFF position. Remove ignitor wire "I" from module. Place ON/OFF rocker switch or wall switch in ON position. If there is no spark at "I" terminal module must be replaced. If there is a spark at "I" terminal, module is fine.



# 16 Reference Materials

## A. Appliance Dimension Diagram

Dimensions are actual appliance dimensions. Use for reference only. For framing dimensions and clearances refer to Section 5.

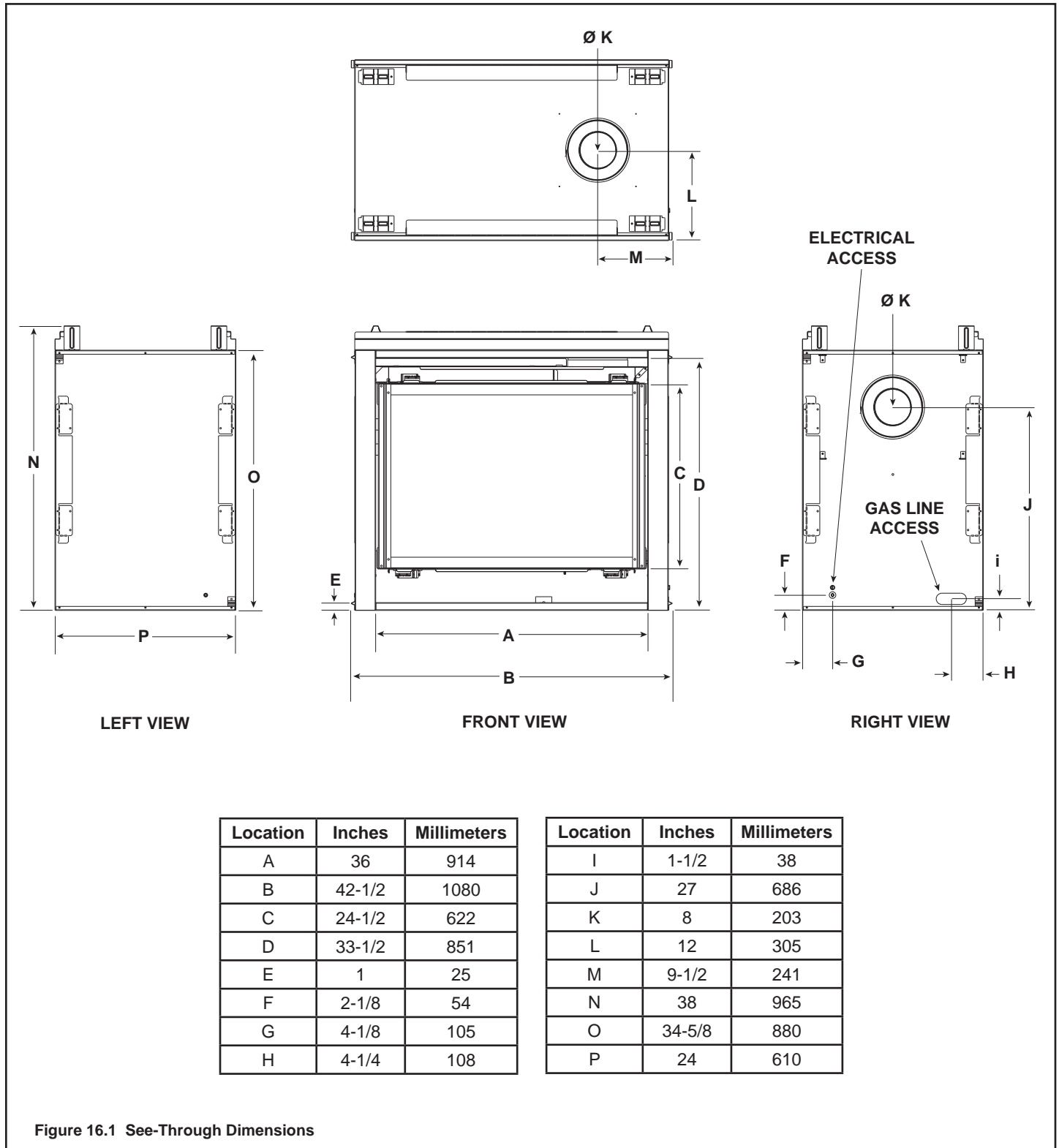

Figure 16.1 See-Through Dimensions

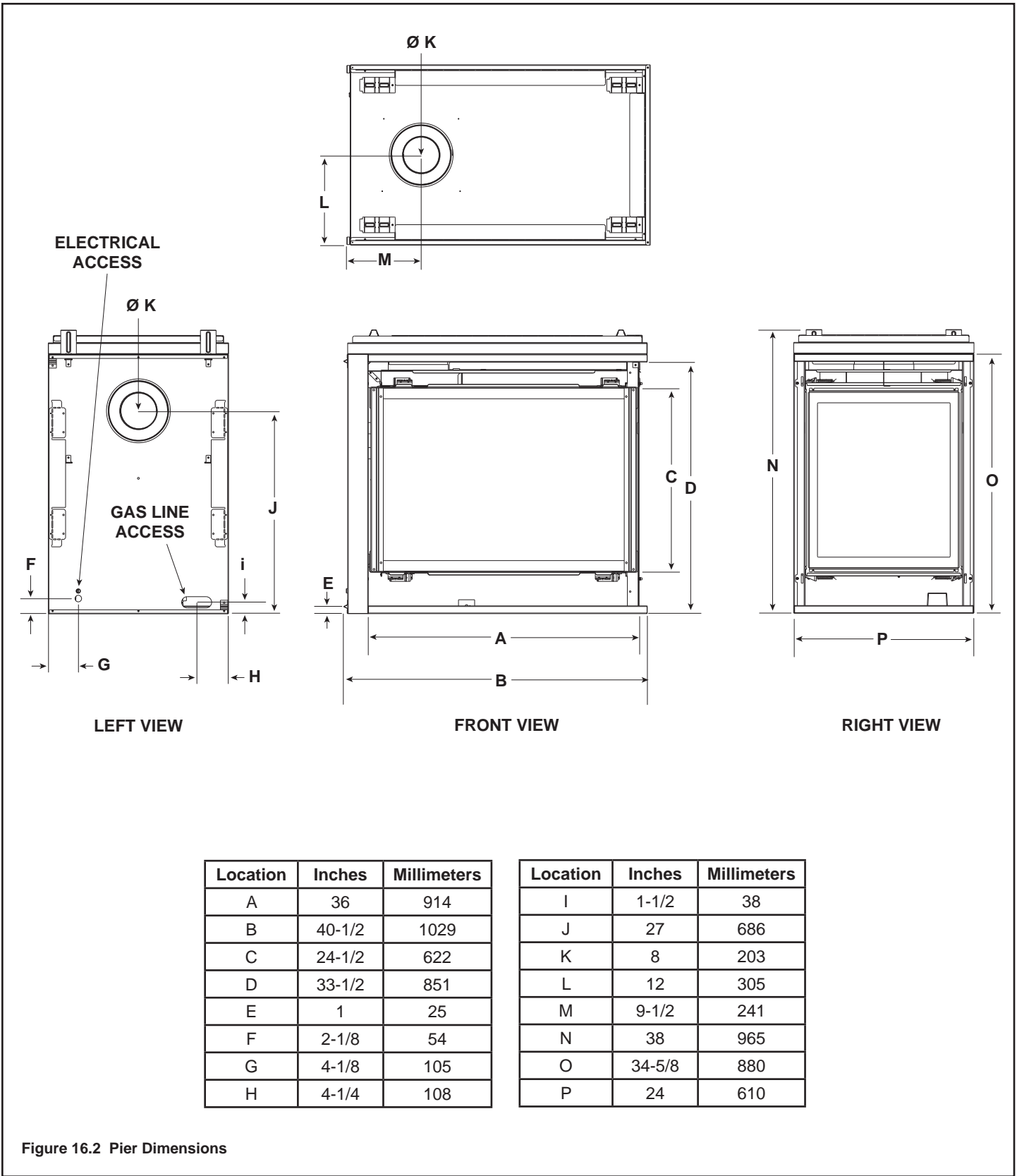
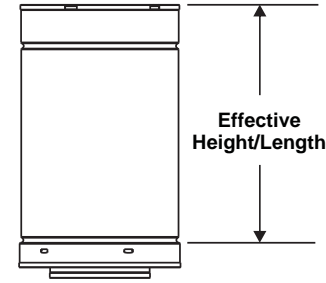

Figure 16.2 Pier Dimensions

## B. Vent Components Diagrams



DVP Pipe (see chart)

Pipe	Effective Length	
	Inches	Millimeters
DVP4	4	102
DVP6	6	152
DVP12	12	305
DVP24	24	610
DVP36	36	914
DVP48	48	1219
DVP6A	3 to 6	76 to 152
DVP12A	3 to 12	76 to 305
DVP12MI	3 to 12	76 to 305
DVP24MI	3 to 24	76 to 610

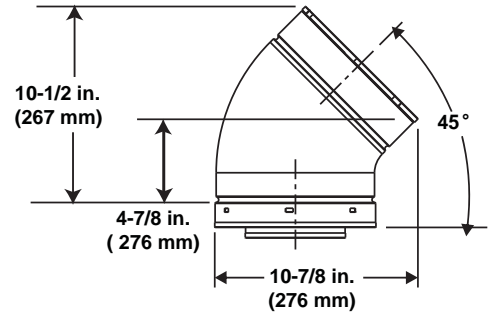

DVP45 (45° Elbow)

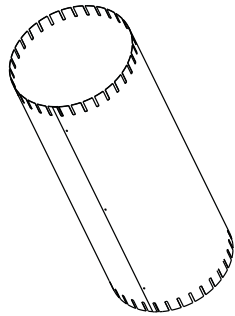

Assembled  
Height: 24 in./610 mm  
Diameter: 10 in./254 mm

DVP-AS2

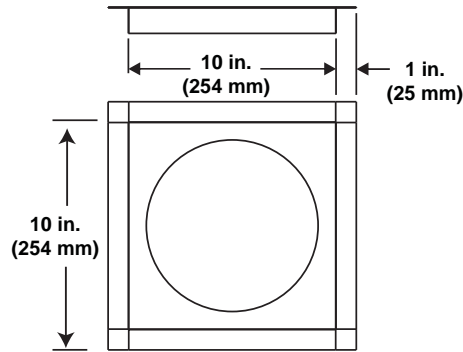

DVP-FS (Ceiling Firestop)

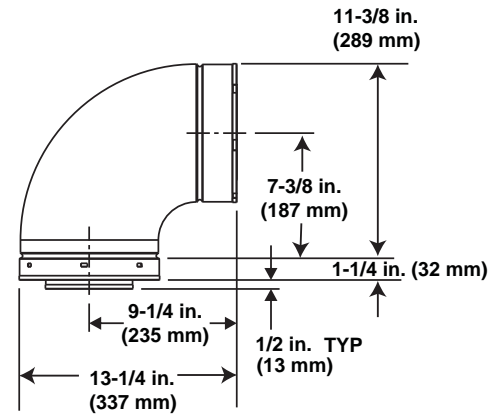

DVP90ST (90° Elbow)

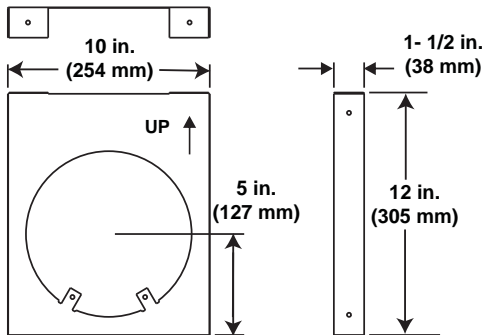

DVP-HVS (Vent Support)

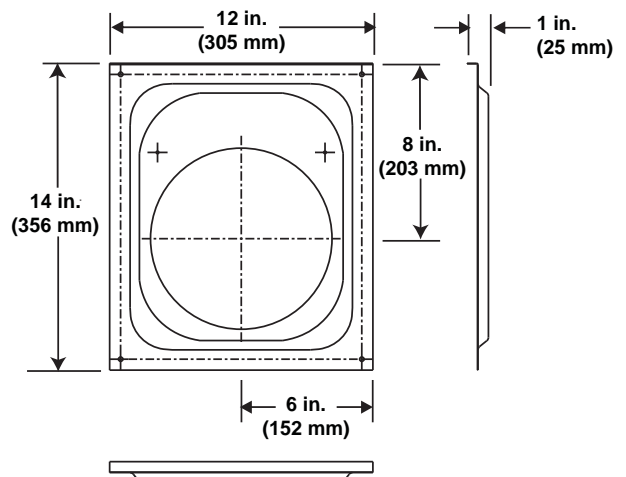

DVP-WS (Wall Shield Firestop)

Figure 16.3 DVP vent components

## B. Vent Components Diagrams (continued)

Note: Heat shields MUST overlap by a minimum of 1-1/2 in. (38 mm). **The heat shield is designed to be used on a wall 4 in. to 7-1/4 in. (102 mm to 184 mm) thick.** If wall thickness is less than 4 in. (102 mm) the existing heat shields must be field trimmed. If wall thickness is greater than 7-1/4 in. (184 mm) a DVP-HSM-B will be required.

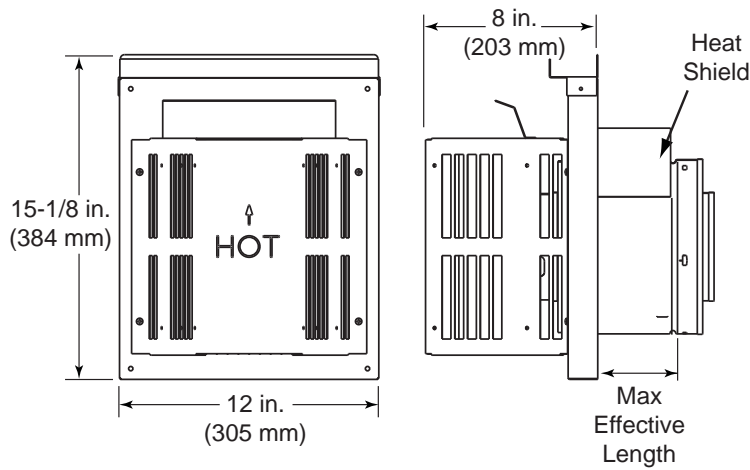

**DVP-TRAP**  
Horizontal Termination Cap

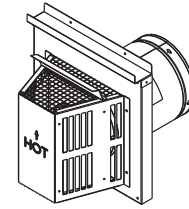

Term Cap	Minimum Effective Length	Maximum Effective Length
Trap1	3-1/8 in.	4-5/8 in.
	79 mm	117 mm
Trap2	5-3/8 in.	9-3/8 in.
	137 mm	238 mm

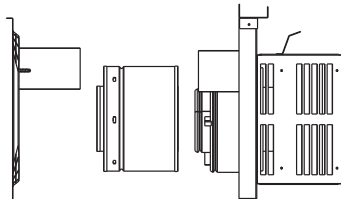

**DVP-TRAP1**

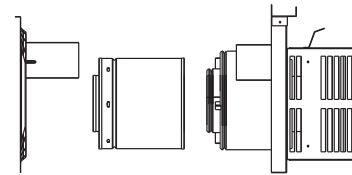

**DVP-TRAP2**

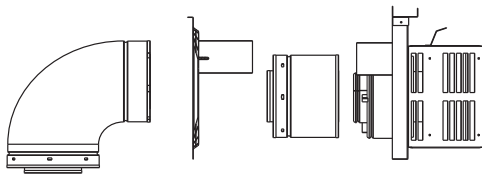

**DVP-TRAPK1**

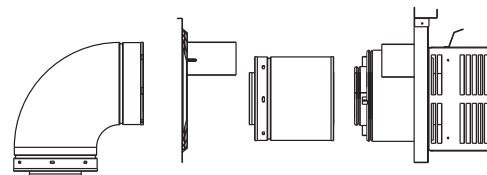

**DVP-TRAPK2**

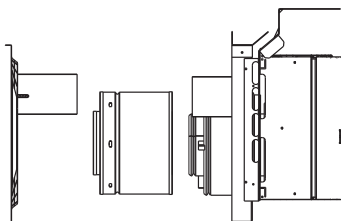

**DVP-HPC1**

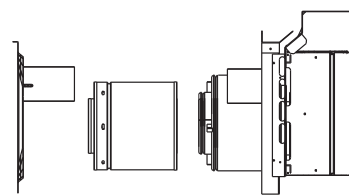

**DVP-HPC2**

Figure 16.4 DVP vent components

**B. Vent Components Diagrams (continued)**

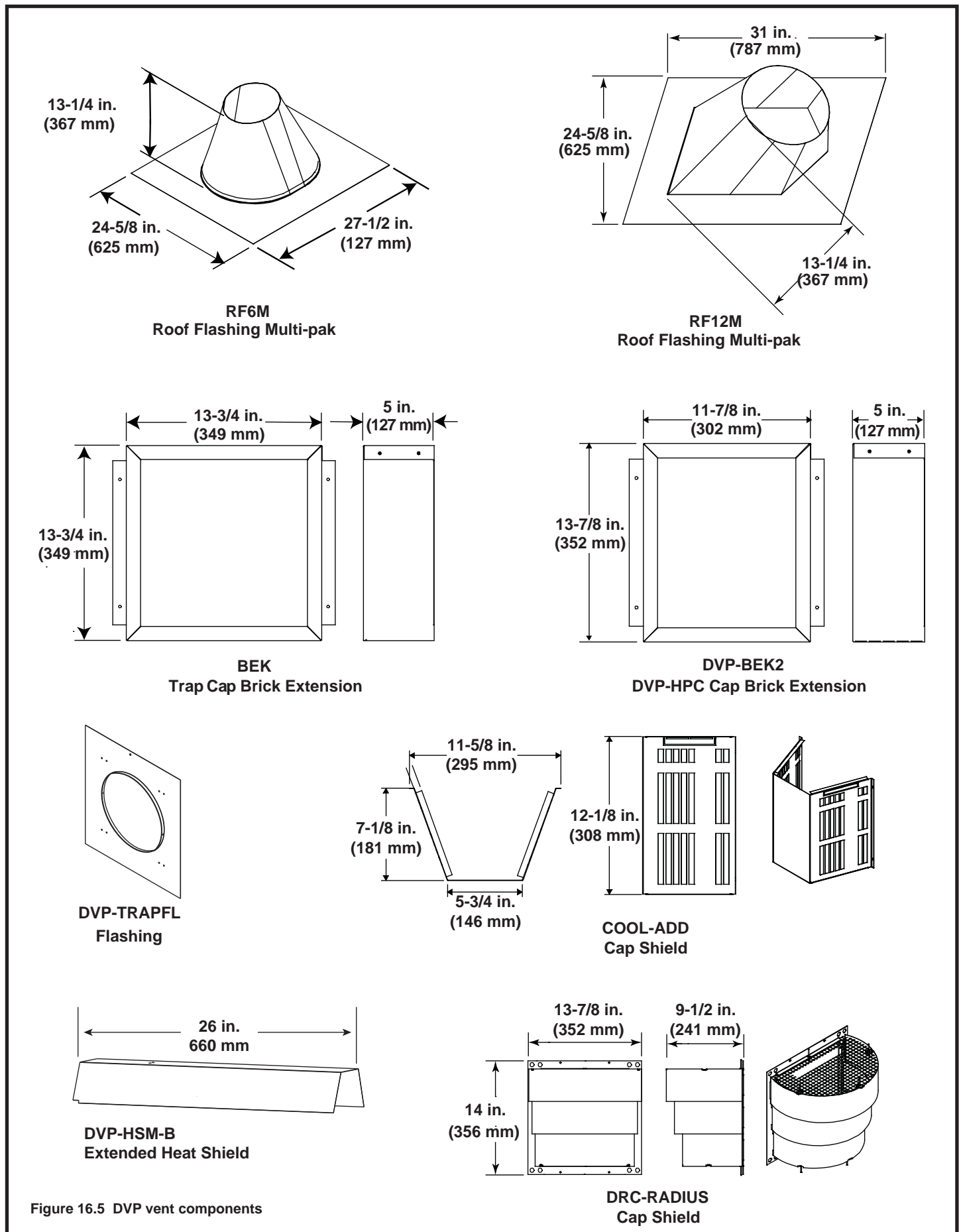

Figure 16.5 DVP vent components

## B. Vent Components Diagrams (continued)

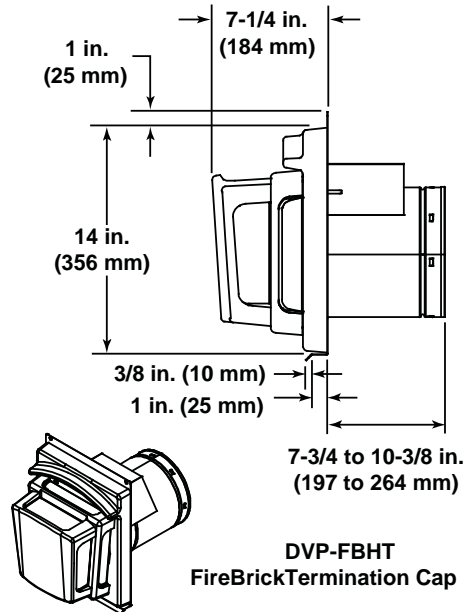
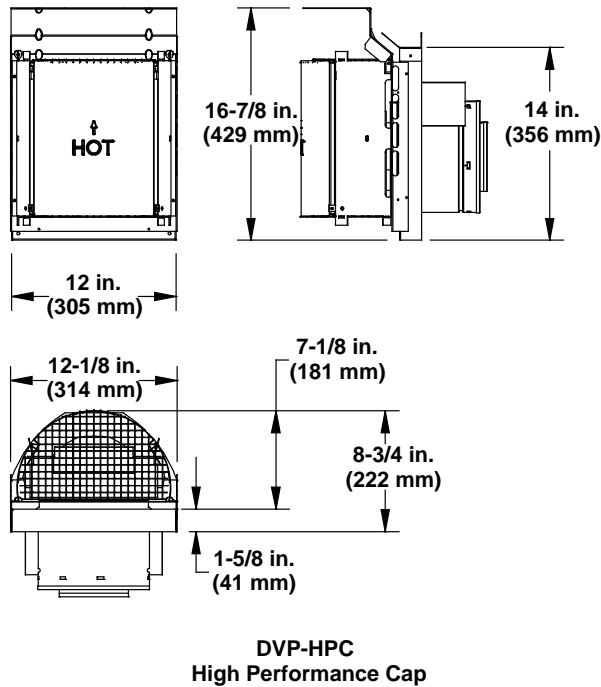
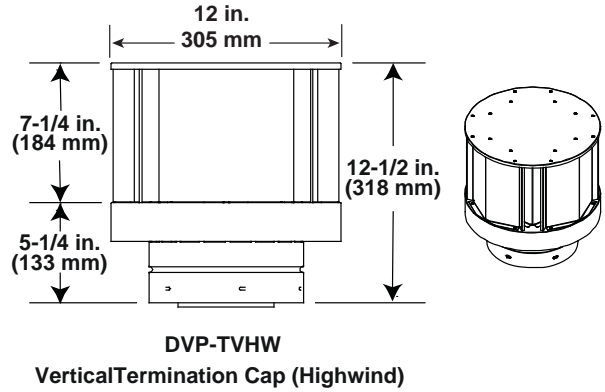
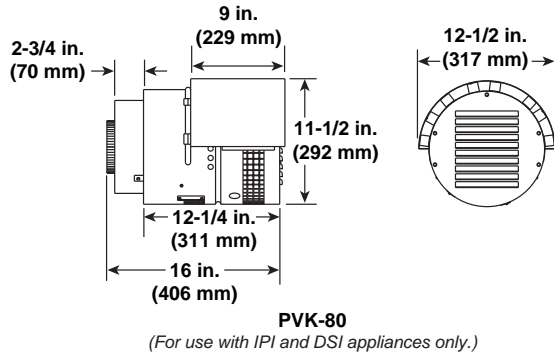
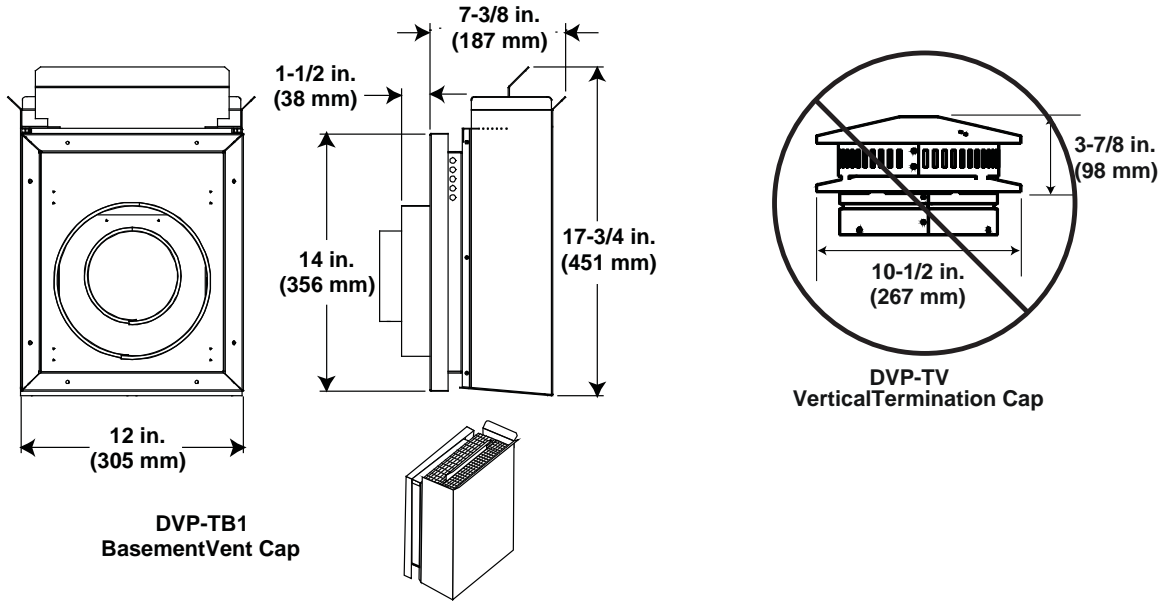
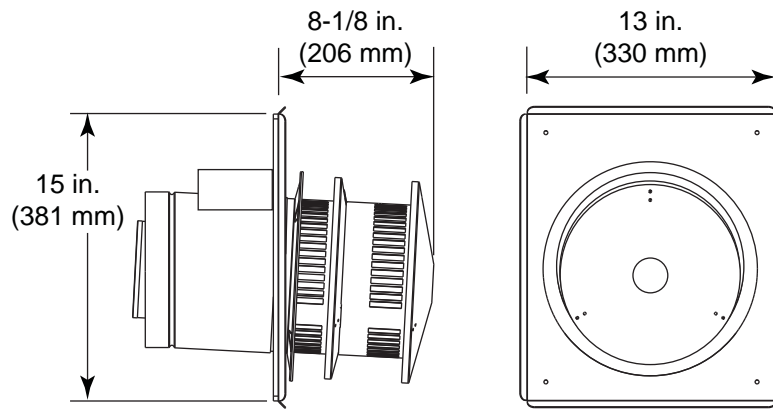

Figure 16.6 DVP Vent Components



## B. Vent Components Diagrams (continued)



**DVP-HRC-SS**

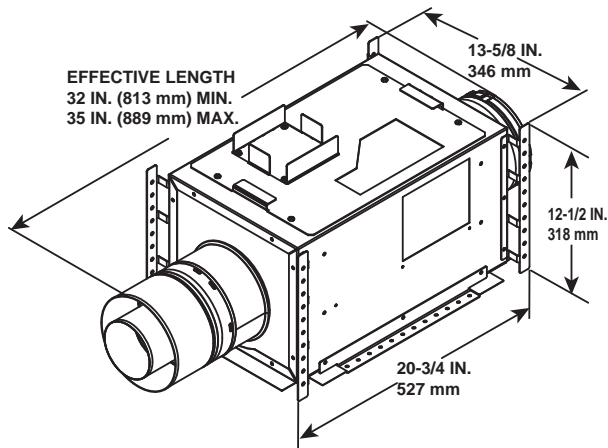

**PVI-SLP  
Power Vent Inline**

Optional Wire Harness	
DESCRIPTION	PART NUMBER
10 ft. PV Wire Harness	PVI-WH10
20 ft. PV Wire Harness	PVI-WH20
40 ft. PV Wire Harness	PVI-WH40
60 ft. PV Wire Harness	PVI-WH60
80 ft. PV Wire Harness	PVI-WH80
100 ft. PV Wire Harness	PVI-WH100

**Note:** Wire harnesses required to power the PVI-SLP connect to the appliance and are ordered separately from PVI-SLP. Contact your dealer to order.

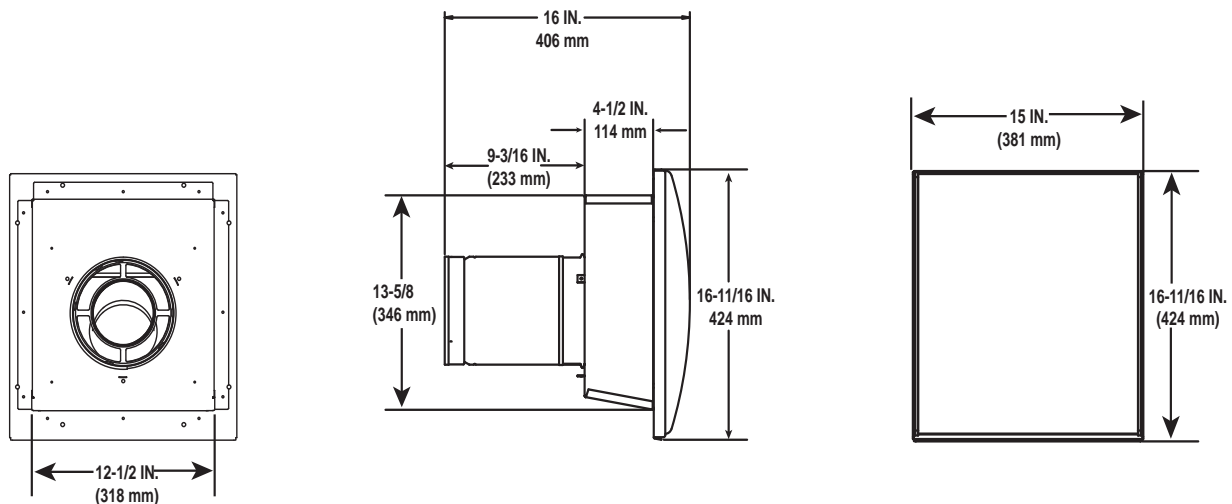

**SLP-LPC  
SLP Low Profile Cap**

**Figure 16.7 Vent Components**

## B. Vent Components Diagrams (continued)

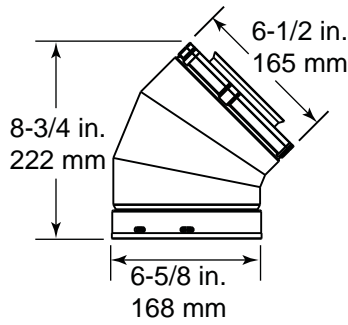

**SLP45**  
45° Elbow

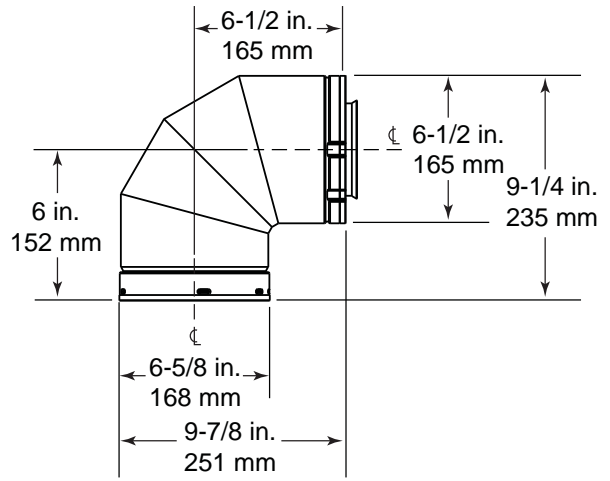

**SLP90**  
90° Elbow

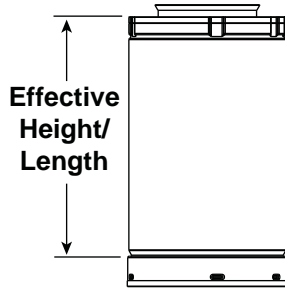

**SLP-PIPE**

**Effective Height/Length**

Pipe	inches	mm
SLP4	4	102
SLP6	6	152
SLP12	12	305
SLP24	24	610
SLP36	36	914
SLP48	48	1219
SLP6A	2 - 6	51-152
SLP12A	2 - 12	51-305
SLP-FLEX-2	24	610
SLP-FLEX-3	36	914
SLP-FLEX-5	60	1524
SLP-FLEX-10	120	3048

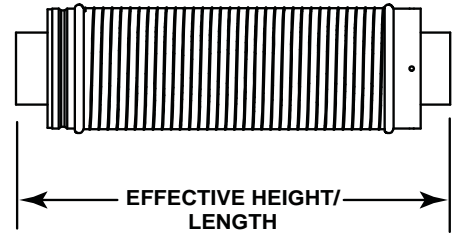

**SLP-FLEX-PIPE**

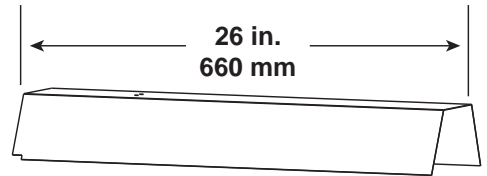

**DVP-HSM-B**  
Extended Heat Shield

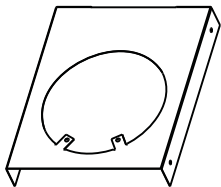

**SLP-HVS**  
Horizontal Pipe  
Support

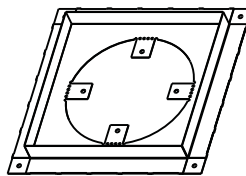

**SLP-FS**  
Ceiling Firestop

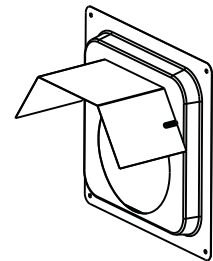

**SLP-WS**  
Wall Shield Firestop

Figure 16.8 SLP Series Vent Components

**B. Vent Components Diagrams (continued)**

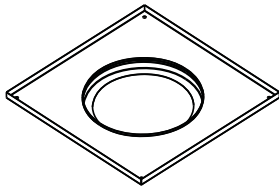

**SLP-DCF-BK**  
Ceiling Firestop  
Black

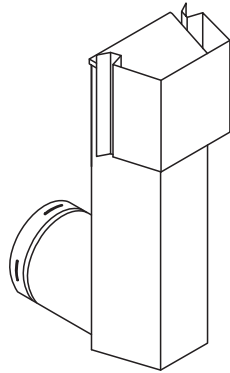

**SLK-SNKD**  
Snorkel  
Termination Cap

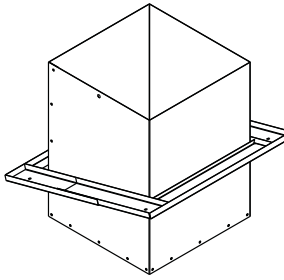

**SLP-CCS-BK**  
Cathedral Ceiling  
Support Box-Black

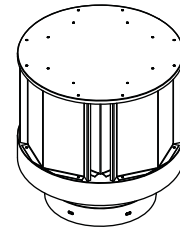

**SLP-TVHW**  
Vertical  
Termination Cap

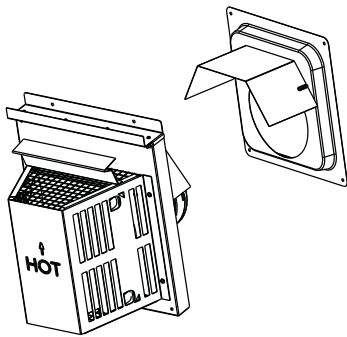

**SLP-TRAP1**  
Horizontal  
Termination Cap

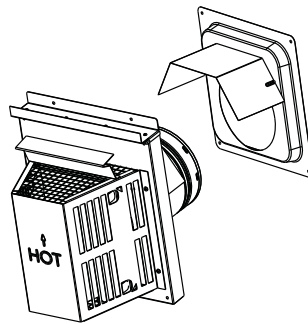

**SLP-TRAP2**  
Horizontal  
Termination Cap

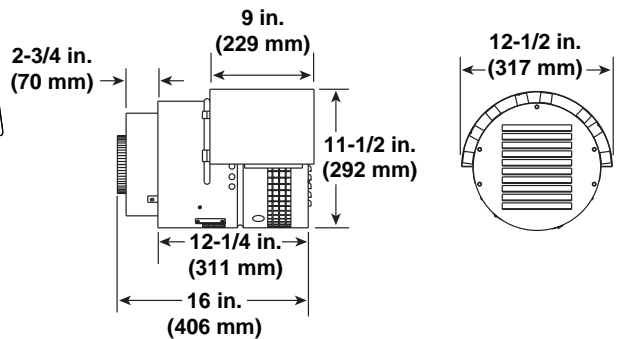

**PVK-80**  
(For use with IPI and DSI appliances only.)

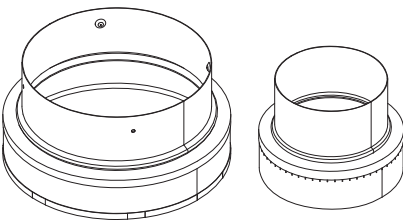

**SL-2DVP**  
Adapter

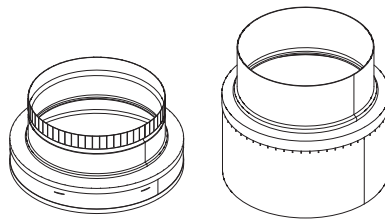

**DVP-2SL**  
Adapter

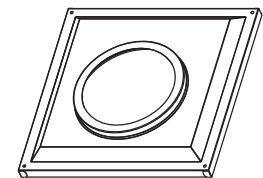

**SLP-WT-BK**  
Wall Thimble-Black

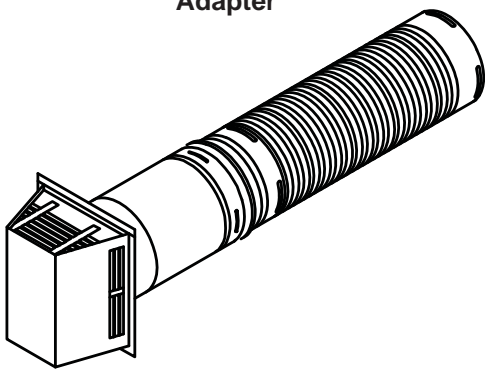

**SLP-FLEX-TRAP**  
Horizontal  
Termination Kit

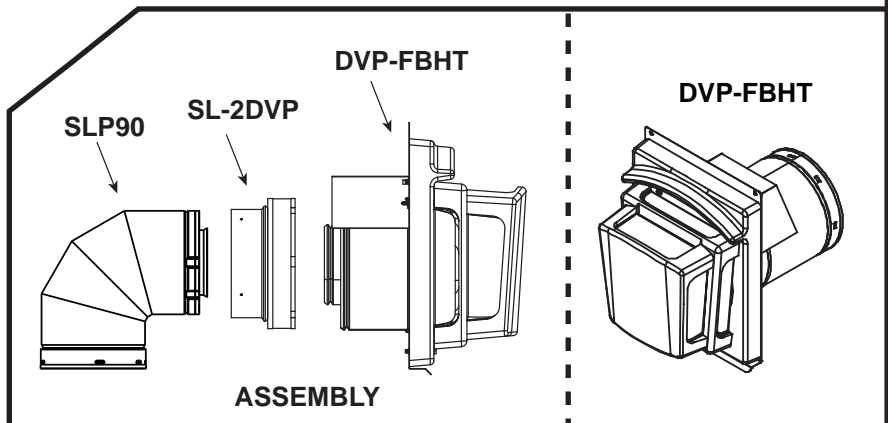

**ASSEMBLY**

Figure 16.9 SLP Series Vent Components

### Log Set Assembly

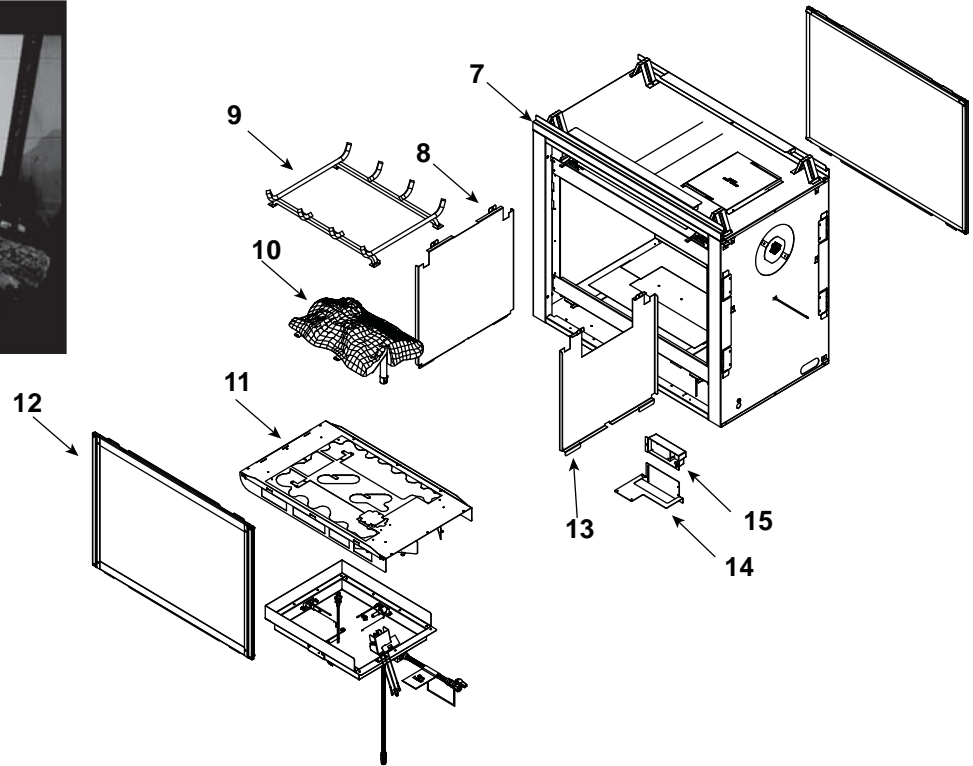
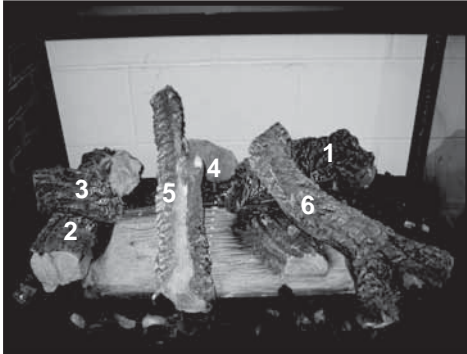

**IMPORTANT: THIS IS DATED INFORMATION.** When requesting service or replacement parts for your appliance please provide model number and serial number. All parts listed in this manual may be ordered from an authorized dealer.



**Stocked at Depot**

ITEM	DESCRIPTION	COMMENTS	PART NUMBER	Stocked at Depot
	Log Set Assembly		LOGS-MSR	Y
1	Log 1		SRV2005-701	
2	Log 2		SRV2005-700	
3	Log 3		SRV2005-702	
4	Log 4		SRV2005-703	
5	Log 5		SRV2005-704	
6	Log 6		SRV2005-705	
7	Sheetrock Ledge (Side)	Qty 2 req	2128-118	
8	Refractory		2129-017	
9	Grate Assembly		2005-012	
10	Burner NG, LP		2005-006	Y
11	Ember Mesh Assembly		2176-008	
12	Glass Door Assembly	Qty 2 req	GLA-750TR	Y
13	Refractory (Air Passage Side)		2129-016	
14	Junction Box Bracket		2128-128	
15	Junction Box		4021-013	Y
	Surround Overlay (contains overlay for top, bottom and sides)		SRV2128-FACE	

Additional service part numbers appear on following page.

### Log Set Assembly

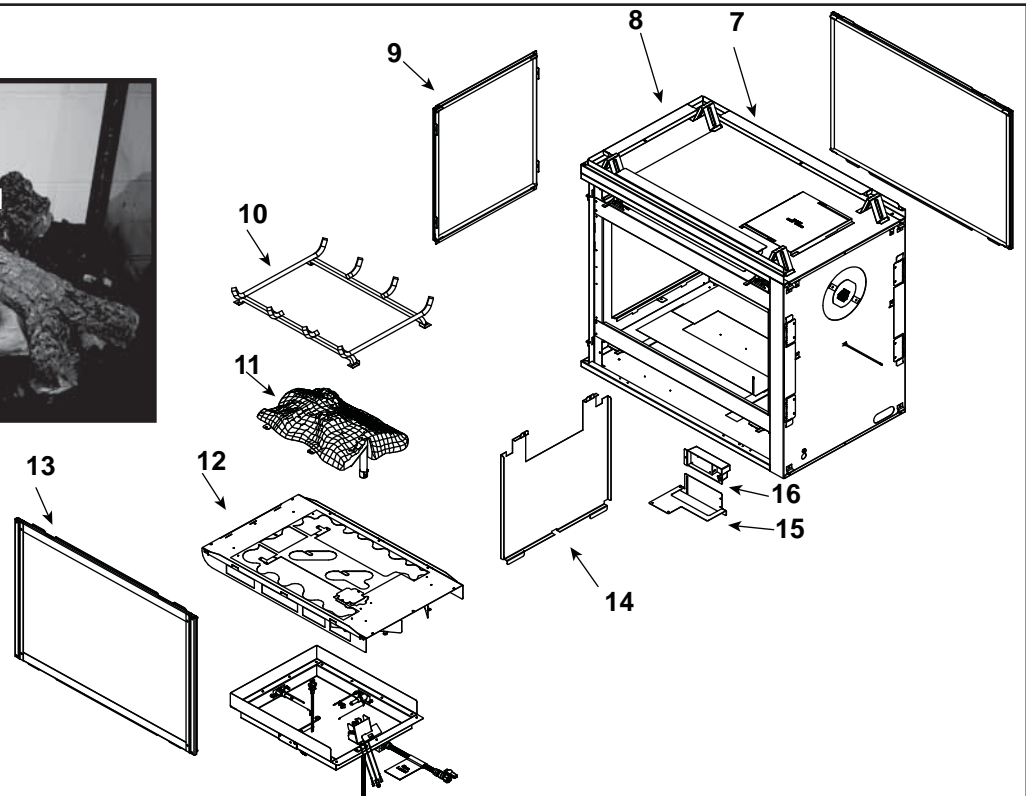
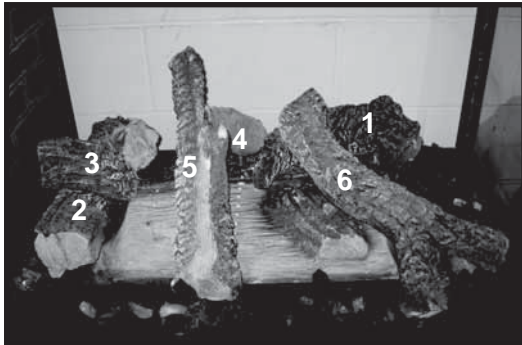

**IMPORTANT: THIS IS DATED INFORMATION.** When requesting service or replacement parts for your appliance please provide model number and serial number. All parts listed in this manual may be ordered from an authorized dealer.



**Stocked at Depot**

ITEM	DESCRIPTION	COMMENTS	PART NUMBER	Stocked at Depot
	Log Set Assembly		LOGS-MSR	Y
1	Log 1		SRV2005-701	
2	Log 2		SRV2005-700	
3	Log 3		SRV2005-702	
4	Log 4		SRV2005-703	
5	Log 5		SRV2005-704	
6	Log 6		SRV2005-705	
7	Sheetrock Ledge (Side)	Qty 2 req	2130-118	
8	Sheetrock Ledge (End)		2130-126	
9	Glass Door Assembly (End)		GLA-2130	Y
10	Grate Assembly		2005-012	
11	Burner NG, LP		2005-006	Y
12	Ember Mesh Assembly		2176-008	
13	Glass Door Assembly	Qty 2 req	GLA-750TR	Y
14	Refractory		2129-016	
15	Junction Box Bracket		2128-128	
16	Junction Box		4021-013	Y
	Surround Overlay (contains overlay for top, bottom and sides)		SRV2130-FACE	

Additional service part numbers appear on following page.

### #17 Valve Assembly

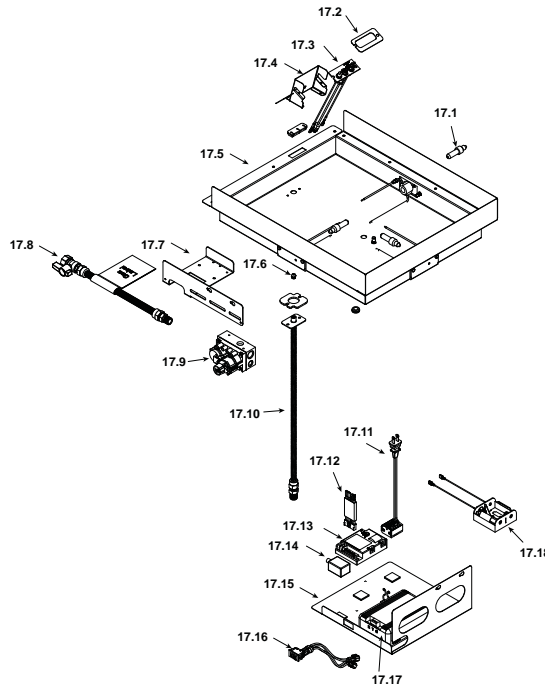

IMPORTANT: THIS IS DATED INFORMATION. When requesting service or replacement parts for your appliance please provide model number and serial number. All parts listed in this manual may be ordered from an authorized dealer.



**Stocked  
at Depot**

ITEM	DESCRIPTION	COMMENTS	PART NUMBER	
17.1	Bulb		700-540	Y
17.2	Wind Baffle		2176-126	
17.3	Pilot Assembly NG		2090-012	Y
	Pilot Assembly LP		2090-013	Y
17.4	Pilot Bracket		2176-118	
17.5	Ember Box Assembly		2005-114	Y
17.6	Orifice NG (#32C)		582-832	Y
	Orifice LP (#50C)		582-850	Y
17.7	Valve Bracket		2176-120	
17.8	Flex Ball Valve Assembly		302-320A	Y
17.9	Valve NG		750-500	Y
	Valve LP		750-501	Y
17.10	Flexible Gas Connector		2005-009	Y
17.11	Connector Block Assembly		2176-019	Y
17.12	Module Wire Assembly		593-590A	Y
17.13	Module		593-592	Y
17.14	Solenoid		HTI-17-006	Y
17.15	Controls Plate		2176-121	
17.16	On/Off Rocker Switch		060-511	Y
17.17	Control Box		HTI-13-007	Y
17.18	Battery Pack		593-594A	Y

Additional service part numbers appear on following page.





